

## 5. GPIB Interface

5.1 Preparation before use .....	5-2
5.2 Remote status and releasing remote control state .....	5-6
5.3 Service request and status structure .....	5-7
5.4 Outline of program message .....	5-18
5.5 Response against query messages .....	5-21
5.6 List of program messages .....	5-22
5.7 Standard execution time .....	5-65
5.8 Error message of external interface .....	5-67
5.9 Reading out measured data .....	5-70
5.10 Operation of data memory .....	5-71
5.11 Response to interface message .....	5-77
5.12 Initialization of GPIB .....	5-78
5.13 Sample GPIB program .....	5-79

## 5.1 Preparation before use

### 5.1.1 GPIB overview

Most of the functions that are operated on the panel can be operated via GPIB with some exceptions. In addition, the user can transfer measurement data to other devices over GPIB. Once measurement data is stored in the data memory, it can be transferred to other devices.

The functions that can be operated via GPIB can also be operated via RS-232 with some exceptions. Practical operation and programming depend on the programming languages and the GPIB driver on the controller side.

For details, refer to the manuals of the programming language being used and the GPIB driver.

#### a) Functions that cannot be operated via GPIB include:

- Turning the power supply ON/OFF
- Initializing to the factory default settings
- Switching between GPIB and RS-232
- GPIB address and message terminator for transmission
- RS-232 baud rate, parity and character length

#### b) Functions that can be operated via GPIB but cannot be operated on the panel include:

- Operation of data memory
- Functions that are specific to the GPIB (status byte, remote/local etc.)

#### c) Applicable standards

- Conforming to IEEE std 488.1-1987, partially conforming to IEEE std 488.2-1992
- Interface functions



**Table 5-1 Interface Functions**

SH1	Completely capable of source handshake
AH1	Completely capable of acceptor handshake
T6	Capable of basic talker, serial poll and listener-defined untalk; not capable of talk only.
L4	Capable of basic listener and talker-defined unlisten; not capable of listen only.
SR1	Completely capable of service request
RL1	Completely capable of remote-local function
PP0	Not capable of parallel poll
DC1	Completely capable of device clear
DT1	Completely capable of device trigger
C0	No controller functions
E1	Open collector drive

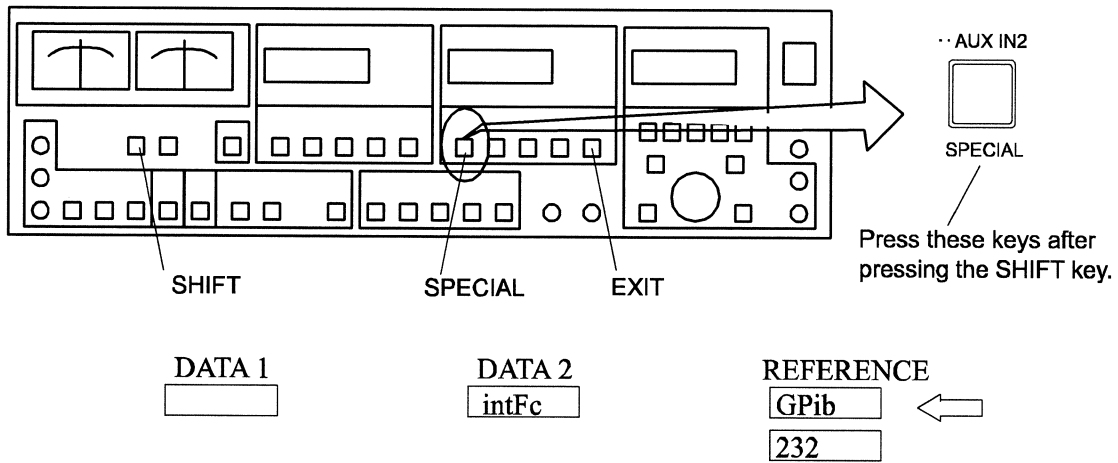
## 5.1.2 Switching to GPIB



Both GPIB and RS-232 cannot be used at the same time. When to use GPIB, follow the procedure below to switch the external interface to GPIB:

- 1) Press the SHIFT + SPECIAL keys.
- 2) Make sure intFc appears on the DATA2 display.  
(Other parameters may be selected using the MODIFY dial.)
- 3) Use the  key to move the blinking digit to the REFERENCE indication section.  
(Or use the  key to return to the DATA2 display.)
- 4) Use the MODIFY dial to select GPIB.
- 5) Press the SHIFT + EXIT keys to return to the previous indication.

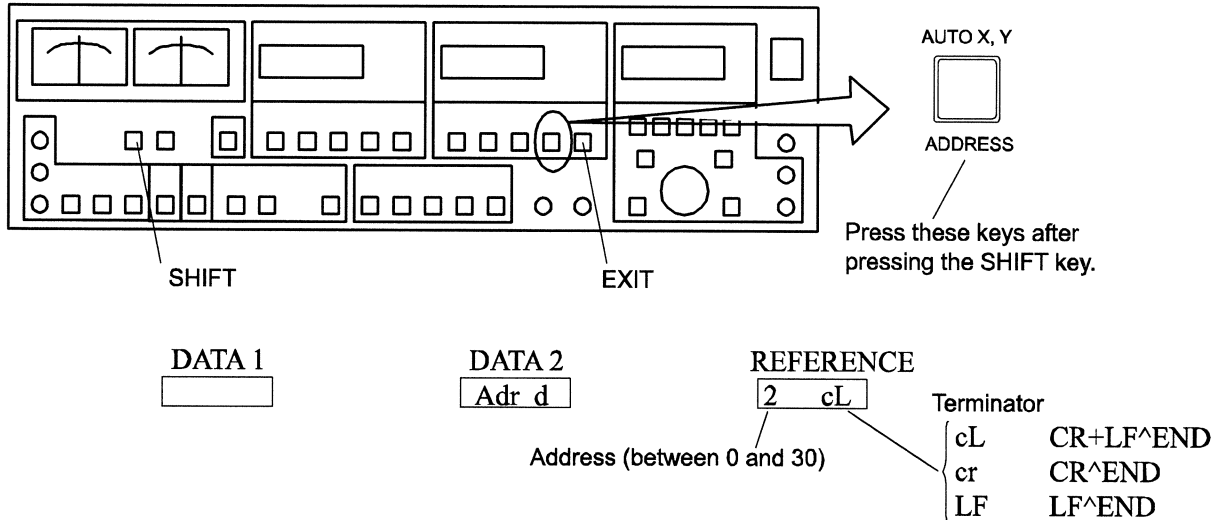

### 5.1.3 Setting the address and message terminator



Before controlling devices via GPIB, each device must be assigned a unique primary address in order to identify them.

The message terminator that indicates the termination of a transmitted message or data may vary with the system. Therefore specify a message terminator according to the system.

Set the address of LI5640 and the message terminator to be used in transmission using the following procedure:

- 1) Press the SHIFT + ADDRESS keys.
- 2) Use the MODIFY dial to set the address.  
GPIB address can be set in the range between 0 and 30.
- 3) Use the  key to move to selection of terminator.  
(Press the  key to return to address setting.)
- 4) Use the MODIFY dial to select the transmission terminator for LI5640. Select one out of CR + LF^END, CR^END and LF^END. ^END specifies to output the END message together with the last code.  
Most systems accept CR + LF^END as the terminator.
- 5) Press the SHIFT + EXIT keys to return to the previous indication.

Further, any of the above terminator functions when LI5640 is receiving data (setting is made from the controller). In addition, an END message may be omitted.

- CR : Carriage return
- LF : Line feed (same as NL or New line)

### 5.1.4 Connecting GPIB cable

A connector for GPIB connection is located on the rear panel.

Connect LI5640 to the GPIB bus line with the GPIB cable as specified by the standard. Before bus connection, turn off the power to every connected device. Securely tighten the connector mounting screws for prevention of loosening.

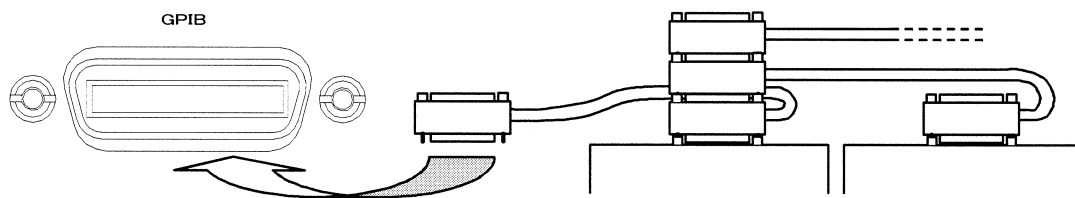
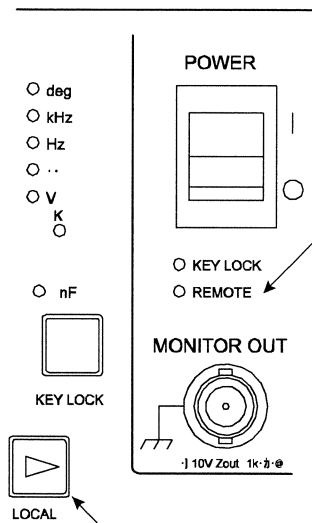

**Fig. 5-1 Connection of GPIB Cables**

### 5.1.5 Precautions on GPIB use

- Before connecting or disconnecting the GPIB connector, turn off the power to every device that is connected to the bus.  
Devices may be damaged if connected or disconnected while the power is supplied.
- When using GPIB, turn on the power to every device that is connected to the bus.
- Up to 15 devices can be connected to one bus, including the controller.
- The length of cabling is subject to the following limit:  
Cable length between devices must be no longer than 4m.  
Total length of all cabling must be within either 2m times the number of interconnected devices or 20m, whichever is shorter.
- Assign a unique address to each device connected to one bus. If different devices are assigned the same address, the devices may be damaged.
- Use a unified message terminator in the system.  
If the message terminator does not match between the talker and the listener, malfunction may occur.
- GPIB is an interface designed for use in relatively good working environment. Avoid use in the environment where the power supply fluctuates or noise is high.

## 5.2 Remote status and releasing remote control state



Press this key after pressing the SHIFT key.

### a) Switching to remote

Select 1 (True, line is at low level) on REN (Remote ENable) and send a program message to LI5640. This will enable remote control state, disabling the local operation on the panel. The REMOTE lamp keeps lighting when the system is in a remote control state.

The system usually stays in a remote control state even after setting completion, depending on the GPIB driver software on controller side.

### b) Switching to local

Pressing the SHIFT + LOCAL keys of LI5640 allows the user to return from remote to local (except when local lockout is active).

The user on the controller side should use either of the following steps to return LI5640 to local:

- Specify the address and send a GTL (Go To Local) interface message.
- Select 0 (False, High level) on REN (Remote ENable line).

GTL brings the specified device into a local state.

Removing the cable from the GPIB connector of device also returns LI5640 to local. However connecting or disconnecting the cable during operation may damage the devices.

### c) Activating local lockout

Once local lockout is activated from controller side, pressing the SHIFT + LOCAL keys cannot return LI5640 to local. This can avoid wrong operation during automatic measuring. To activate local lockout, use the following operation:

- Send an LLO (Local LockOut) interface message.

LLO activates local lockout on every device that is connected to the bus and has the local lockout function.

To deactivate local lockout, set REN to 0.

The method of programming depends on the GPIB driver software on controller side.

For details, refer to the instruction manual of the use's driver.

## 5.3 Service request and status structure

### 5.3.1 Outline of status report

GPIB has a function that advises device status to a controller.

For example, it is available for interrupting by transmitting a service request (SRQ) to the controller when automatic sensitive setting of LI5640 is completed. When reading out the related register of LI5640, it is possible to know the status on the time.

#### [Status Byte]

The device has some pairs of status data, and they are summarized in the status byte of the device.

#### [Sending of a service request]

If a bit of the service request enable register is set to 1, then the system will send a service request (SRQ) when each status bit of status byte becomes 1.

#### [Capture of an event]

Device condition is shown on the condition register, its change is recorded in the event register. If the corresponding bit of the event enable register is set to 1, each bit of the event register will be summarized in the specific one bit of the status byte.

LI5640 has total three event registers including the standard event status register. The event register and the condition register can be read.

When \*PSC command is used, it can be select whether clearing of enable register or keeping of previous conditions at power on.

#### [Clasp of queue condition]

The device is waiting queue to retain the information of waiting output. The status byte has a status bit that indicates whether the queue has information or not.

LI5640 prepares MAV bit that indicates the queue condition of output of response message and EAV bit that indicates queue condition of error code (number and message).

**[CAUTION: Performance is reduced in frequent read out status]**

If a serial poll is performed frequently for checking the device condition without a service request, the resource of controller is consumed by performing of serial poll. If the status is queried by a query message frequently, the controller performance (operation speed) is not only reduced but also receiving device of query. Perform a query appropriate period.

### 5.3.2. Status byte and sending a service request

A status byte register has summary of device conditions.

If a corresponding bit of a service request enable register is set to 1, then the system will send a service request (SRQ) when the status bit becomes 1.

The status byte can be read by following methods.

- Serial poll
- Query by \*STB? of common command (the response message is decimal integer). When serial poll is performed, each bit is not cleared in reading status byte register without RQS bit is reset.

Serial poll is a GPIB function in which controller assigns an address to read the status byte of each GPIB device. The method of programming depends on the language of the controller and GPIB driver software.

Service request enable register can execute setting and query using following messages.

- Setting : \*SRE of common command
- Query : \*SRE? of common command

The data to be set and the response data are decimal integers in which the weight of the bit set to one in each register was added.

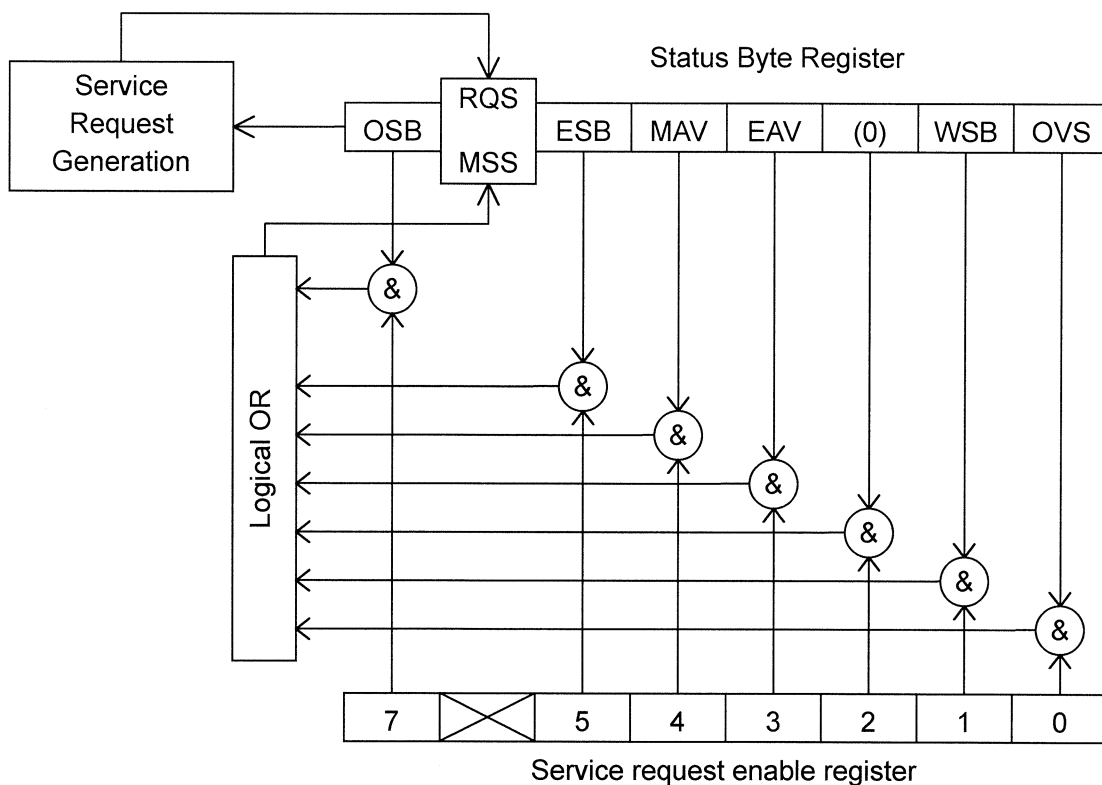

**Fig5-2 Enabling SRQ transmission**

**Table5-2 Status Byte Register**

Bit (weight)	Mnemonic	Description
7(128)	OSB	Summary of operation event register If any bit of operation event register becomes 1, this bit will be set to 1, and if all bits become 0, then this bit will be cleared to 0.
6(64)	RQS	Request service ( at serial poll *Note1) If any of permitted bit of the status byte becomes 1 and service request occurs, RQS is set to 1 and will be cleared to 0 by reading serial poll.
	MSS	Master summary status ( at *STB? *Note1) If any of permitted bit of status byte becomes 1 and service request occurs , MSS is set to 1 and will be cleared to 0. MSS is not cleared with serial poll.
5(32)	ESB	Summary of standard event status register If any of permitted bit of standard event status register becomes 1, ESB is set to 1, and if all of permitted bit of standard event status become 0, ESB will be cleared to 0.
4(16)	MAV	Available for output of response message. If response message is written to output queue against query message and output valid, MAV is set to 1. If output queue will be empty by assigning the talker and reading the response message, MAV will be cleared to 0.
3(8)	EAV	Error occur ( available for output error message) If error occurs and error number and error code are written to error queue and then it available for output, EAV will be set to 1. If an error number and a message are read by a query message "ERROR?" and then error code queue will be empty, EAV will be cleared to 0.
2(4)		Always 0. ( Not used)
1(2)	WSB	Summary of warning event register If any of permitted bit of warning event register becomes 1, WSB is set to 1, and if all of permitted bit of warning event register become 0, ESB will be cleared to 0. (*Note 1)
0(1)	OVS	Summary of over level event register If any of permitted bit of over level event register becomes 1, OVS is set to 1, and if all of permitted bit of over level event register is set to 0, ESB will be cleared to 0. (*Note 2)

\*Note 1: Bit 6 will be RQS if status byte is read by serial poll.

Bit 6 will be MSS in response message against query message " \*STB?"

\*Note 2: "permitted" means that "the bit against enable register is set to 1".

### 5.3.3 Detail structure of status data

#### a) Outline

The previous status prior to summarizing in a status byte register exists in several event registers. In every event register, exists a corresponding enable register, and summary into status byte can be permitted or prohibited by bits. Please note that the event register will not be cleared to 0 even if the status byte register is read by serial poll or query message.

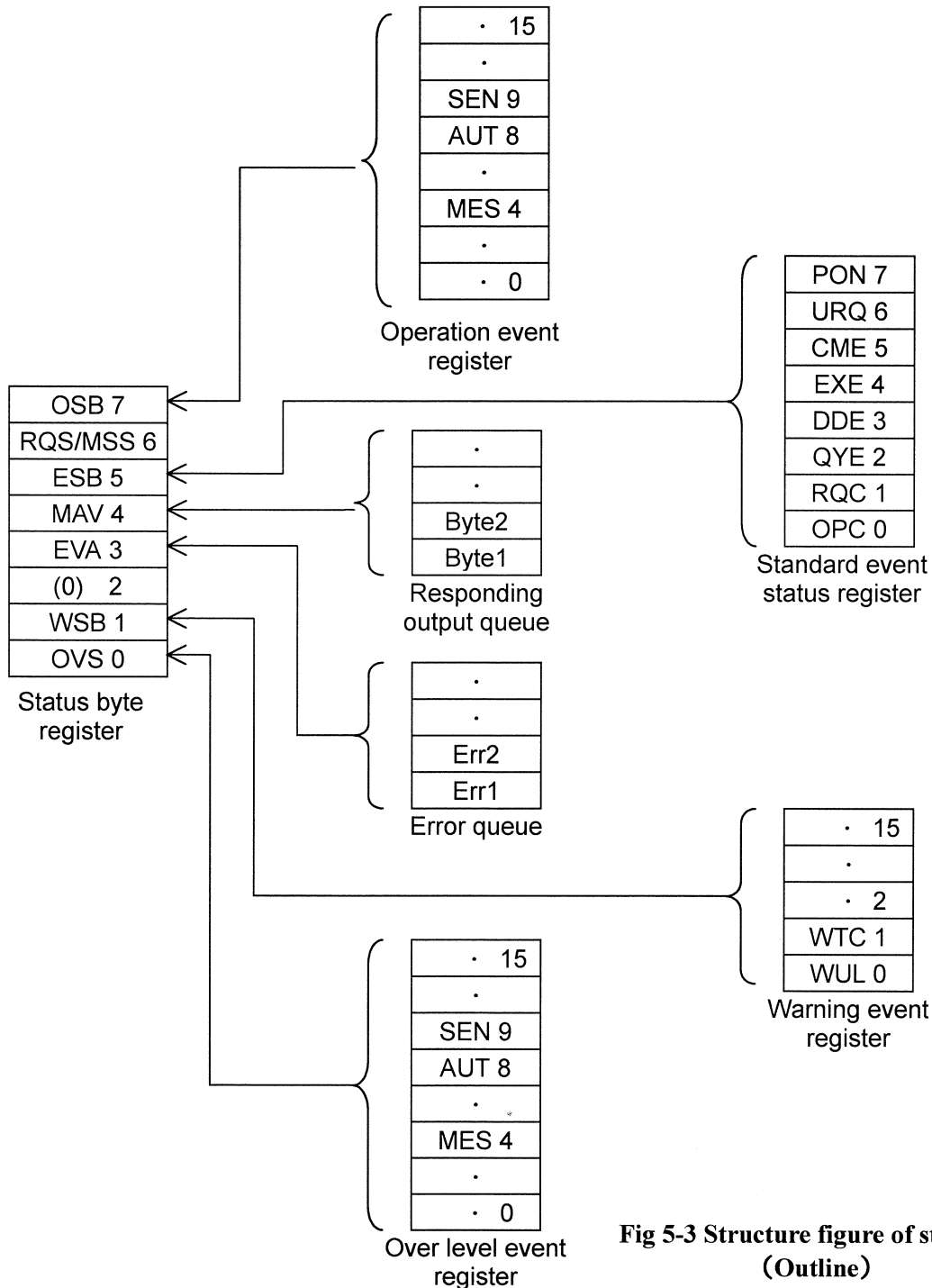

Fig 5-3 Structure figure of status (Outline)

**b) Standard event status register and related registers**

The standard event status register is a register that is commonly given to every GPIB device that conforms to IEEE-488.2 standards. This register express the condition of a device as shown in table5-3 "Assign of standard event register".

A standard event status register can be queried with the following query messages.

- \*ESR? of common command ( Response data will be in decimal integer)

Every bit of standard event status register is cleared in following conditions.

- Standard event status register is read.
- Common command \*CLS (clear status) is sent.

Every bit of standard event status register can be summarized into an ESB bit of the status byte register by setting the corresponding bit of the standard event status enable register to 1,

A standard event status enable register can be set or queried using the following messages where the data is the total of the weight of each factor that are set to 1.

- Setting : \*ESE of common command. (The setting data will be in decimal integer).
- Query : \*ESE? of common command. (The responding data will be in decimal integer).

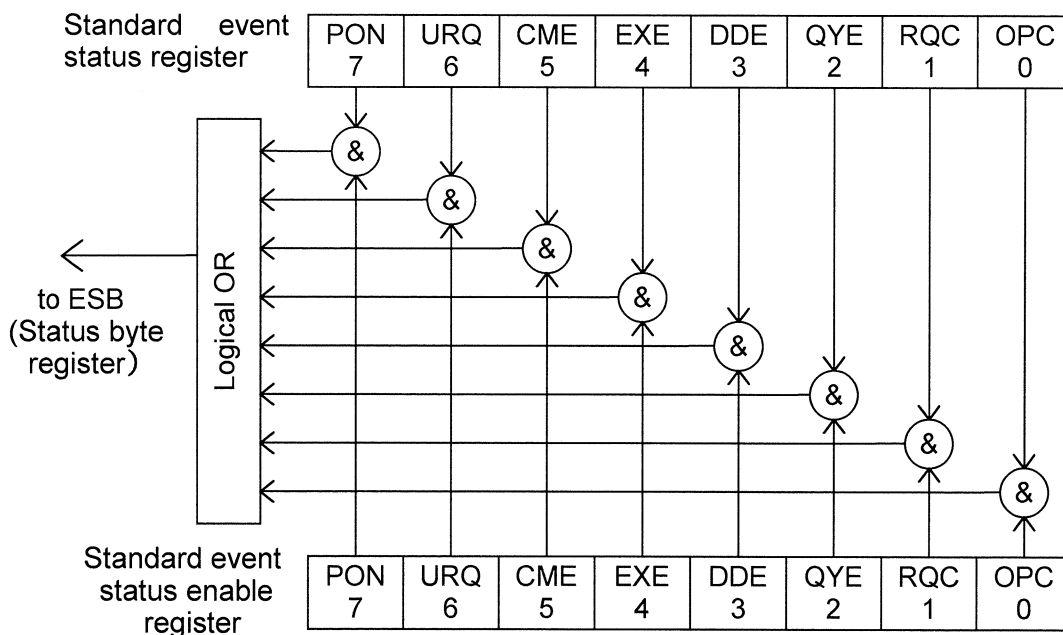

**Fig 5-4 Standard event status register**

Table 5-3 Bit assignment of standard event status registers

Bit (Weight)	Mnemonic	Description
7(128)	PON	<b>Power on</b> When power is on, PON is set to 1. When clearing to 0 by read out, it remains 0 until the power is changed again.
6(64)	URQ	<b>User request</b> Always 0 ( not used)
5(32)	CME	<b>Command error</b> This will be set to 1 if any syntax error is detected in the program message.
4(16)	EXE	<b>Execution error</b> This will be set to 1 if the program data is out of setting possible range or specified setting is not possible due to the current condition.
3(8)	DDE	<b>Device defective error</b> This will be set to 1 if the inherent error occurs in the device. In this device, this will be set if error code queue is over flow
2 (4)	QYE	<b>Query error</b> This will be set to 1 if any of the following occurs. <ul style="list-style-type: none"> <li>● Reading is attempted when the queue contains no response message. (RS232C does not yield this error.)</li> <li>● Query capacity limit(1024 characters) is exceeded.</li> <li>● A next program message was received when sending of response message to a query has not been completed.</li> </ul>
1 (2)	RQC	<b>Request for control authority</b> Always 0 ( not used)
0(1)	OPC	<b>Operation completed</b> If common command *OPC is sent during following command is executed, when all of operation is completed, OPC will be set to 1. If recording to data memory, automatic setting (AUTOSET) and automatic sensitive setting are not executed, OPC setting is executed at once.

### C) Operation event register and related register

LI5640 has operation condition register that always reflects vary of operation conditions of this device. This register can be queried by the following query message.

- OPCR? ( the response data will be decimal integer)

Every bit of operation condition register changes from 1 to 0( completion of operation),Corresponding bit of operation event register will be set to 1.

Operation event register can be queried by the following query message.

- OPER? ( the response data will be decimal integer)

Every bit of operation event register is cleared to 0 by the following conditions.

- Read operation event register.
- Common command \*CLS( clear status) is sent.

Every bit of operation event register is summarized into the OSB bit of status byte register by setting corresponding bit of an operation event enable register to 1.

An operation event enable register can be set or queried using the following messages where the data is the total of the weight of each factor that is set to 1.

- Setting : OPEE (the setting data will be in a decimal integer)
- Query : OPEE? (the response data will be in decimal integer)

**Table 5-4 Bit assignment of operation condition register**

Bit(weight)	Mnemonic	Description
15		Always 0 (not used)
14		
13		
12		
11		
10		
9(512)	SEN	Under automatic sensitive setting ( SENSITIVE AUTO)
8(256)	AUT	Under automatic setting( AUTO SET)
7		Always 0 (not used)
6		
5		
4(16)	MES	Under recording to data memory
3		Always 0 ( not used)
2		
1		
0		

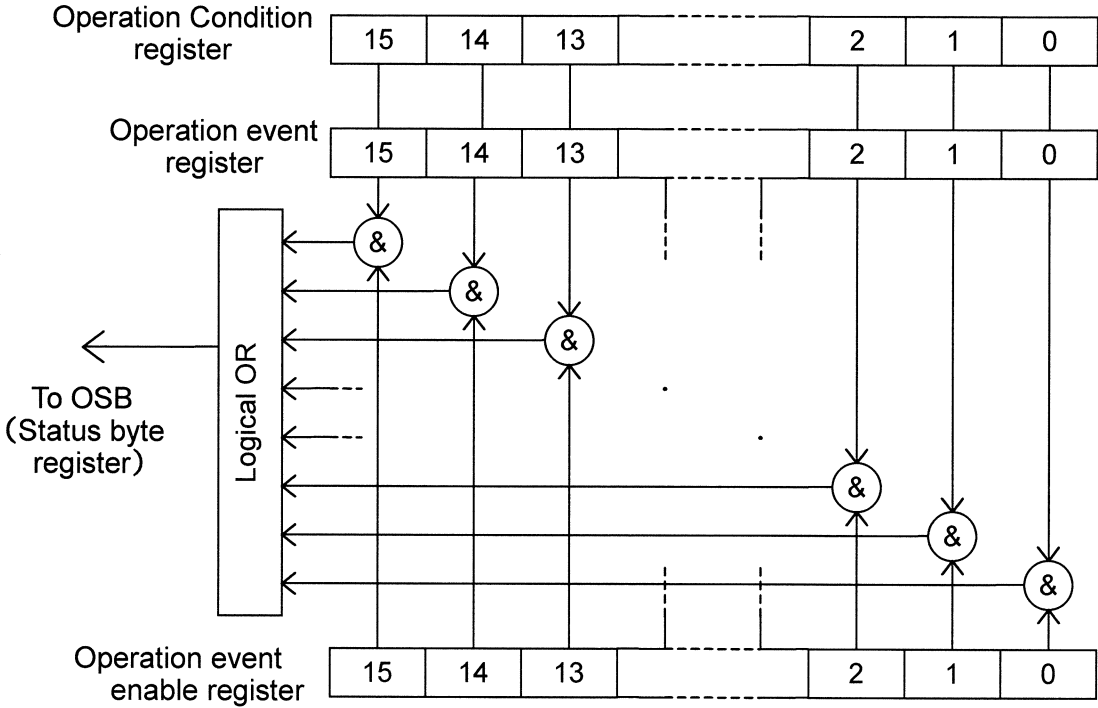

**Fig 5-5 Operation Status**

Even any system of operation, warning and over level, relation of three conditions register, event register and enable register are same.

Program message of direct setting or clear program are not exist.

**d) Warning event register and related registers**

LI5640 has a register that reflects varying of warning conditions.

This register can be queried by the following query message.

- WRCR? (the response data will be in a decimal integer)

Every bit of warning condition register changes from 0 to 1, corresponding bit of warning register will be set to 1.

Warning event register can be queried by the following query message.

- WRER? ( Response data will be in a decimal integer)

Every bit of warning event register is cleared to 0 by the following occurs:

- When warning register is read.
- When common command \*CLS (Clear status) is sent.

Every bit of warning register can be summarized into WSB bit of status byte register by setting the corresponding bit of warning event enable register to 1.

Warning event enable register can be queried and set by the following program messages where the data is the total of the weight of each factor that is set to 1.

- Setting : WREE (the setting data will be in a decimal integer)
- Query : WREE? ( the response data will be in a decimal integer)

**Table 5-5 Assignment of warning condition register**

Bit(weight)	Mnemonic	Description
15		↑ Always 0 (not used) ↓
14		
...		
...		
2		
1(2)	WTC	It is impossible to lock as time constant is too small compare with frequency and roll off if reference signal source( SOURCE) is SIGANL.
0(1)	WUL	Not synchronized to reference signal.( lit on UNLOCK lamp)

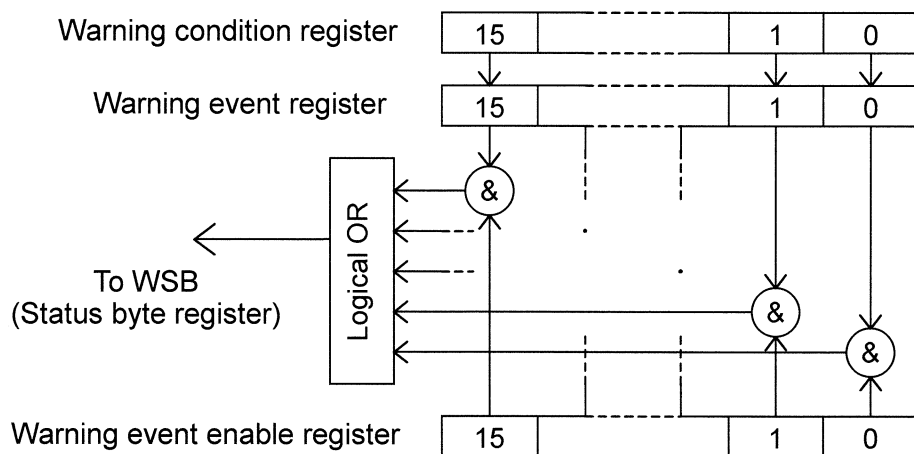

**Fig 5-6 Warning status**

### e) Over level event register and related register

LI5640 has register that always reflects change of an over level condition of a signal system. This register can be queried by the following query messages.

- OVCR? (Response data will be into a decimal integer)

If every bit of over level condition register changes from 0 to 1, corresponding bit of over level event register will be set to 1.

Over level event register can be queried by the following query messages:

- OVER? ( the response data will be in a decimal integer)

Every bit of over level event register is cleared to 0 by the following conditions.

- When over level event register is read.
- When common command \*CLS(Clear status) is sent.

Every bit of over level event register can be summarized to the OVS bit of status byte register by setting the corresponding bit of over level event enable register to 1.

Over level event enable register can be set or queried by the following program message where the data is the total of weight of each factor that is set to 1.

- Setting: OVEE ( the setting data will be in a decimal integer)
- Query: OVEE? ( the response data will be in a decimal integer)

**Table 5-6 Assignment of over level condition register**

Bit(Weight)	Mnemonic	Description
15		↑ Always 0 ( not used) ↓
...		
6		
5(32)	OR2	DATA 2 Ratio display, AUX IN1 is over level condition.
4(16)	OR1	DATA 1 Ratio display, AUX IN1 is over level condition.
3(8)	OD2	DATA2 is display over level condition.
2(4)	OD1	DATA1 is display over level condition.
1(2)	OSE	Over level condition in the middle stage.
0(1)	OIE	Over level condition in the input stage.

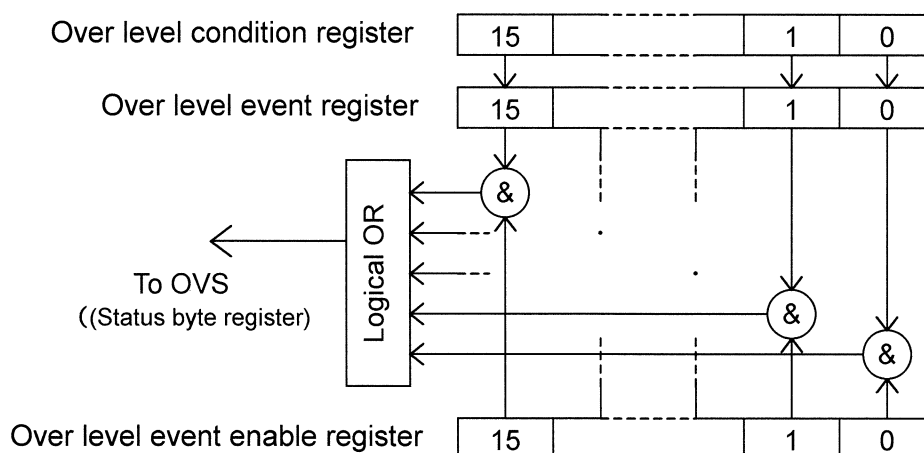

**Fig5-7 Over level status**

## 5.4 Outline of program message

The operation procedure is same as operation from the panel when LI5640 is controlled by external interface (GPIB or RS232C).

Refer to the description of the panel operation procedure in the external operation.

### a) Syntax of program messages

A program message can be sent from a controller when LI5640 is controlled by a remote operation. The program message consists of a command message that instructs setting and a operation, and a query message that queries a setting or condition.

Program messages { Command message : Setting and an operation instruction  
Query messages : Query a setting or conditions

The syntax of a program message is shown below.

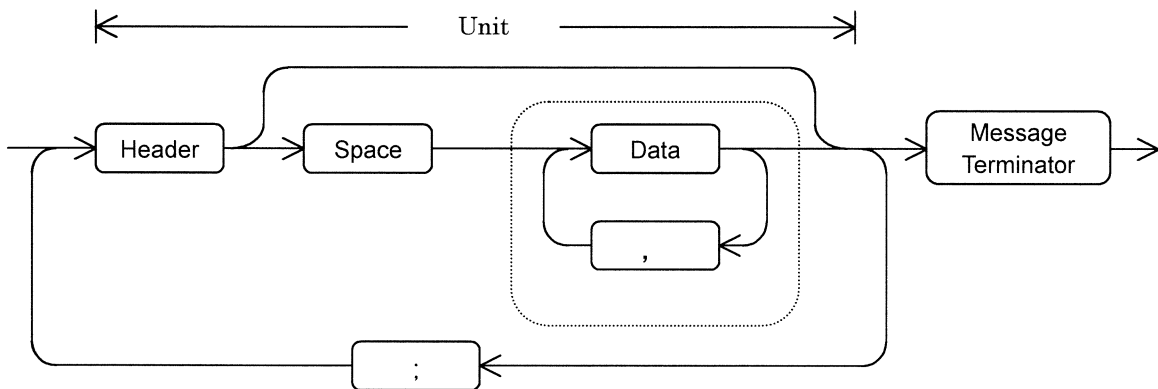

Fig5-8 Constructions of program messages (Outline)

Used character code is ASCII 7 bit code.

If this device is received a data, upper case letters and lower case letters are not classified. The parity bit is ignored.

Main constructed elements of program messages are the header, data and the terminator.

- Header(Command program header or query program header)  
Alphabet character strings that express a function. A query header is character strings that is appended “?” at the end of command header in a corresponding command
- Data ( Program data)  
Instructs a detail of function.  
No header data is also existing. (In simple operation instruction)  
The data can be set into an integer, real or exponential form.  
Example : 3 +123 -5.6 .789E+3

- Message terminator

Indicates the end of program message. This command is used for following commands.

CR LF, CR, LF, CRLF^END, LF^END, ^END

^END means that END message (EOI line of bus is LOW) is sent with just before characters(byte).

- Space

If the data is exit, it must be punctuated by one character or more of space character (ASCII code is 20H) between the header and the data.

- Comma

If the data number is plural, every data must be punctuated by a comma (.). Available for putting space before and after a space.

- Semicolon

When a plural program message is sent at one time, each unit must be punctuated by semicolon. The space can be put before and after semicolon.

## **b) Input buffer**

A program message can be sent continuously within input buffer capacity (1024 words).

A program message is stored in an input buffer temporary, and when terminator is receive, an input is interpreted in order and executed. Null (00H) and CR, LF can not be not entered an input buffer.

When a program message is exceeded a capacity of an input buffer, a message within capacity of an input buffer is executed, however, a part exceeded an input buffer message is destructed.

When a program message is interpreted and irregular header or date is detected, error occurs. At this time, input buffer is cleared, and after cleared it, a program messages are not executed

After completed the interpretation and the execution, the input buffer is cleared and it will be made an accepted condition of next input.

**c) Compatible messages**

A compatible messages of NF conventional model(510A or 5600A) is prepared. It is easy to correct a program on a controller side by using a compatible message when replacing to LI5640 from the conventional models.

However, as there are different between both models about functions, a perfect compatibility is impossible. Please note that a compatible message is required semicolon (;) for difference between conventional models and this lock-in amplifier.

	Message of conventional models (5610A/5600A)	Compatible messages	LI5640 Original messages
When plural program messages are sent continuously, semicolon";" have to be put between each unit.	Possible to neglect	Necessary	Necessary
A space between a header and a data	Possible to neglect	Possible to neglect	Necessary
Position of "?" for a query header	Front of a command header Example: ?OFQ	Front of a command a header Example: ?OFQ	End of a command header Example: FREQ?
Addition for a response message	Possible	Possible	Impossible

## 5.5 Response against query messages

If a query message is sent to LI5640, its response message is put to output queue of LI5640.

Its message is obtained if a data from LI5640 is received.

If plural messages are sent at one time, a response message against each query message is punctuated by a semicolon";" and put to the output queue. However, When the total of a response string exceeds 1024 characters, the error occurs. The terminator is impossible to use.

Example:

If | of " · · Resmmm,Re|snmn, · · " is limit, characters before Resmmm are put to the output queue and after Resnnn are disappeared.

An output queue is cleared when a controller sends next message by not receiving a response message that is put on the output queue. Send next message after receiving all response messages when a program message including a query message is sent

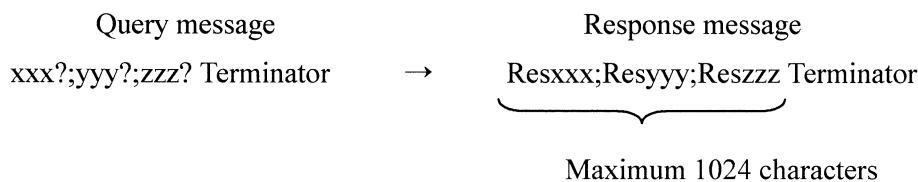

Approximate syntax of response message are shown the below.

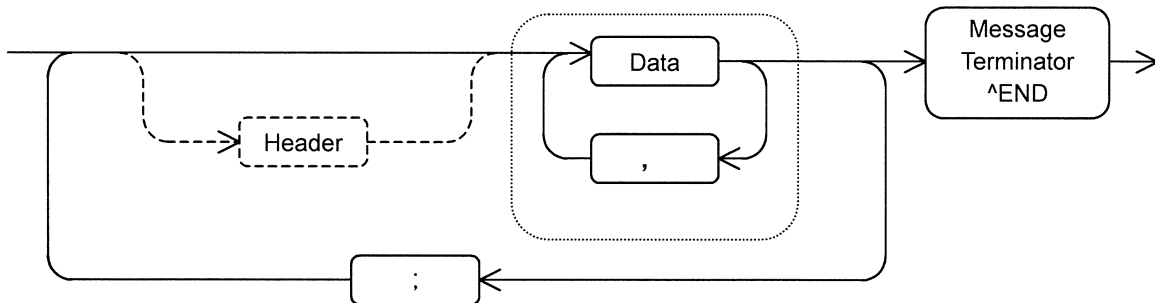

**Fig5-9 Structures of response messages (Outline)**

Message terminator is CRLF, CR or LF that is selected by the panel. END message is output with the last character (EOI line of bus will be LOW.)

### [Response message against a compatible message]

When querying only by a compatible message of 5610B/5600A, it is available for output of a header. It is available for a prohibition of header output, and a header can not be set when power is on.

## 5.6 List of Program messages

### 5.6.1 List of Program messages

[Complement of the list]

Items	Header	Operation and range of data
Indicates an item name that conforms the indicating item name on the panel name	Indicates a command header if a command exists, or indicates a header of query if a query only exists.	<b>&lt; Indicates a description of operation &gt;</b> Command : Indicates an example of command message. Query : Indicates an example of a query message. Response : Indicate an example of response message. syntax : Indicates a data endian when a command or a query has plural data. Range : Indicates a data range in a command, a query and a response. INIT : Indicates a setting by INIT command.

- In case of a corresponding query message is existing, if putting “?” after a command message header, it will be query message header.
- A space is required between a header and a data followed a header.
- Plural data must be punctuated by comma “,”.

[Initial value of GPIB at power on (parameters that can not be set from the panel)]

OTYP	A kinds of read out measurement data	1,2 (DATA1, DATA2)
OSMP	Output sampling period of continuous data output	1,0
OSTR	Start and stop of continuous data output	0 (stop)
DTYP	A kind of recording data	2 (DATA1, DATA2)
DSIZ	Record length	0 (2K data)
DNUM	Number of recording data memory number	0
DSMP	Recording sampling period	5(1ms)
TENB	Permission/prohibition of external trigger input TRIGGER IN	0 (prohibition)
SPTS?	Number of recording sampling	0
*PSC	Power on status clear flag	No change

 **About parameters that can be set from the panel** ➔ Refer to [Table 3-2 The list of initial values].

An initial value of enable register depends on setting of power on status clear flag.

A setting of power on status clear at a delivery is zero(0).

## a) REFERENCE system-related messages

Items	Header	Operation and Data Range
PHASE	PHAS	<b>&lt;Setting and Query of Phase offset&gt;</b> Command : PHAS 90.0 (+180.00 is changed to -180.00) Query : PHAS? Response : 90.00 Range : -180.00 to +179.99 [degrees] (and +180.00 degrees) At INIT : 0.00
PHASE-AUTO	APHS	<b>&lt;Execution of automatic phase offset command&gt;</b> Command : APHS Query : None
FREQ	FREQ	<b>&lt;Setting and query of internal-oscillator frequency&gt;</b> Command : FREQ 1.0 E3 Query : FREQ? Response : 1.0000E+03 Range : 0.0005 Hz to 105.00 kHz At INIT : Not changed <b>Note:</b> It is not the measured frequency. The reference signal frequency under measurement is read using Query which reads measured value, such as DOUT?.
AMPTD	AMPL	<b>&lt;Setting and Query of amplitude(OSC OUT)&gt;</b> Command : AMPL 0.1,1 Syntax : AMPL x, i Query : AMPL? Response : 0.100,1 Range : x = Amplitude [Vrms] 0.0 m to 50.0 m (Resolution 0.1m) 0 m to 500 m (Resolution 1m) 0.00 to 5.00 (Resolution 0.01) i = Amplitude range 0 50 mV 1 500 mV 2 5 V At INIT : Not changed
nF	HARM	<b>&lt;Setting and Query of harmonic order&gt;</b> Command : HARM 2 Query : HARM? Response : 2 Range : 1 to 19999 (integer) At INIT : 1

## a) REFERENCE system-related messages

2/2

Items	Header	Operation and Data Range
SOURCE	RSRC	<b>&lt;Setting and Query of reference signal&gt;</b> Command : RSRC 0 Query : RSRC? Response : 0 Range : 0 REF IN 1 INT OSC 2 SIGNAL At INIT : Not changed
EDGE	REDG	<b>&lt;Setting and query of reference signal synchronous edge&gt;</b> Command : REDG 0 Query : REDG? Response : 0 Range : 0 SINE POS 1 TTL POS 2 TTL NEG At INIT : Not changed

## b) Messages of SIGNAL INPUT system

Items	Header	Operation and setting range
SIGNAL	ISRC	<b>&lt;Setting and query of measured signal input&gt;</b> Command : ISRC 0 Query : ISRC? Response : 0 Range : 0 A 1 A - B 2 I (10 <sup>6</sup> ) 3 I (10 <sup>8</sup> ) At INIT : Not changed
COUPLING	ICPL	<b>&lt;Setting and query of measured signal input coupling&gt;</b> Command : ICPL 0 Query : ICPL? Response : 0 Range : 0 AC 1 DC At INIT : Not changed
GROUND	IGND	<b>&lt;Setting and query of measured signal ground&gt;</b> Command : IGND 0 Query : IGND? Response : 0 Range : 0 FLOAT 1 GROUND At INIT : Not changed

## c) AUTO SET Command

Items	Header	Operation and setting range
AUTO SET	ASET	<b>&lt;Excution of automatic setting&gt;</b> Command : ASET(Ignored during execution) Query : None

## d) FILTER-related messages

Items	Header	Operation and setting range
LINE LINE×2	ILIN	<b>&lt;Setting and query of line frequency noise filter&gt;</b> Command : ILIN 0 Query : ILIN?            Response : 0 Range : 0 THRU (not used) 1 LINE 2 LINE x 2 3 LINE & LINE x 2 At INIT : THRU
LINE (SHIFT+)	IFRQ	<b>&lt;Setting and query of line frequency&gt;</b> Command : IFRQ 0 Query : IFRQ?            Response : 0 Range : 0 50Hz 1 60Hz At INIT : No change
LPF THRU	ITHR	<b>&lt;Setting and Query of low-pass filter on/off&gt;</b> Command : ITHR 0 Query : ITHR?            Response : 0 Range : 0 Used 1 through (not used)(Lit) At INIT : used (Unlit)

## e) DYNAMIC RESERVE-related messages

Items	Header	Operation and setting range
DYNAMIC RESERVE	DRSV	<b>&lt;Setting and query for dynamic reserve&gt;</b> Command : DRSV 1 Query : DRSV?            Response : 1 Range : 0 HIGH 1 MEDIUM 2 LOW At INIT : LOW

## f ) SENSITIVITY-related messages

Items	Header	Operation and setting range
SENSITIVITY	VSEN	<p><b>&lt;Setting and query of voltage sensitivity&gt;</b>  Command : VSEN 23  Query : VSEN?                      Response : 23  Range : 0    2nV                      10    5<math>\mu</math>V                      20    10mV            1    5nV                      11    10<math>\mu</math>V                      21    20mV            2    10nV                      12    20<math>\mu</math>V                      22    50mV            3    20nV                      13    50<math>\mu</math>V                      23    100mV            4    50nV                      14    100<math>\mu</math>V                      24    200mV            5    100nV                      15    200<math>\mu</math>V                      25    500mV            6    200nV                      16    500<math>\mu</math>V                      26        1V            7    500nV                      17        1mV            8        1<math>\mu</math>V                      18        2mV            9        2<math>\mu</math>V                      19        5mV</p> <p>When having measured noise density, setting ranges differ.  At INIT : 1V</p>
SENSITIVITY	ISEN	<p><b>&lt;Setting and query of current sensitivity&gt;</b>  Command : ISEN 23  Query : ISEN?                      Response : 23  Range :                                      10    5 pA                      20    10 nA            1    5 fA                                      11    10 pA                      21    20 nA            2    10 fA                                      12    20 pA                      22    50 nA            3    20 fA                                      13    50 pA                      23    100 nA            4    50 fA                                      14    100 pA                      24    200 nA            5    100 fA                                      15    200 pA                      25    500 nA            6    200 fA                                      16    500 pA                      26        1 <math>\mu</math>A            7    500 fA                                      17        1 nA            8        1 pA                                      18        2 nA            9        2 pA                                      19        5 nA</p> <p>It will become an error if 0 is specified.  A setting range differ. with current-voltage conversion gain.  When having measured noise density, setting ranges differ.</p> <p>At INIT : 1 <math>\mu</math>A</p>
AUTO (SENSITIVITY)	ASEN	<p><b>&lt;Execution of automatic sensitivity setting&gt;</b>  Command : ASEN(Nothing is done during execution.)  Query : None</p>

## g) TIME CONSTANT-related messages

Items	Header	Operation and setting range
TIME CONSTANT	TCON	<b>&lt;Setting and query of time constant&gt;</b> Command : TCON 9 Query : TCON?            Response : 9 Range : 0    10 $\mu$ s            10    1 s 1    30 $\mu$ s            11    3 s 2    100 $\mu$ s           12    10 s 3    300 $\mu$ s           13    30 s 4    1 ms                14    100 s 5    3 ms                15    300 s 6    10 ms               16    1 ks 7    30 ms               17    3 ks 8    100 ms              18    10 ks 9    300 ms              19    30 ks At INIT : 100ms
AUTO (TIME CONSTANT)	ATIM	<b>&lt;Execution of automatic time constant setup&gt;</b> Command : ATIM Query : None
SYNC	SYNC	<b>&lt;Setting and query of synchronous filter&gt;</b> Command : SYNC 0 Query : SYNC?            Response : 0 Range : 0    off (Conventional filter) 1    on (Synchronous filter) At INIT : off
SLOPE	SLOP	<b>&lt;Setting and query attenuation slope&gt;</b> Command : SLOP 1 Query : SLOP?            Response : 1 Range : 0    6 dB/oct 1    12 dB/oct 2    18 dB/oct 3    24 dB/oct At INIT : 24 dB/oct

## h) Measurement data display (DATA1,DATA2)-related messages

Items	Header	Operation and setting range
DATA1 DATA2	DDEF	<b>&lt;Setting and query of display parameter&gt;</b> Command : DDEF 1, 2      Syntax: DDEF i, j Query : DDEF? 1      Response : 2 Range : i = 1 DATA1 = 2 DATA2 i = 1      i = 2 j = 0    X      Y 1    R $\theta$ 2    NOISE    AUX IN1 3    AUX IN1    AUX IN2 At INIT : DATA1 R, DATA2 $\theta$
NORMALIZE	NORM	<b>&lt;Setting and query of normalized display&gt;</b> Command : NORM 1 Query : NORM?      Response : 1 Range : 0 off (Conventional display) 1 dB 2 % At INIT : off
STD	VSTD	<b>&lt;Setting and query of voltage normalized-standard&gt;</b> Command : VSTD 51.2E-6 Query : VSTD?      Response : 51.20E-6 Range : 1.0000 nV to 1.0000 V At INIT : 1.0000 V
	ISTD	<b>&lt;Setting and Query of current normalized-standard&gt;</b> Command : ISTD 51.2E-12 Query : ISTD?      Response : 51.20E-12 Range : 1.0000 fA to 1.0000 $\mu$ A At INIT : 1.0000 $\mu$ A
NOISE	NOIS	<b>&lt;Setting and query of noise measurement smoothing coefficient&gt;</b> Command : NOIS 1 Query : NOIS?      Response : 1 Range : 0 $\times$ 1 1 $\times$ 4 2 $\times$ 16 3 $\times$ 32 4 $\times$ 64 At INIT : Not changed

## h) Measurement data display(DATA1,DATA2)-related messages

2/2

Items	Header	Operation and setting range
X OFFSET ON Y OFFSET ON	OFSO	<b>&lt;Setting and Query of offset on/off&gt;</b> Command : OFSO 1, 1    Syntax : OFSO i, j Query : OFSO? 1    Syntax : OFSO? i    Response : 1 Range : i= 1 X    j= 0 off 2 Y               1 on At INIT : X, Y (both off)
X OFFSET Y OFFSET	OFFS	<b>&lt;Setting and Query offset value&gt;</b> Command : OFFS 1, 10.0    Syntax : OFFS i, u Query : OFFS? 1    Syntax : OFFS? i    Response: 10.00 Range : i= 1 X 2 Y u = Offset value (-100.00 to +100.00 [%] of sensitivity) At INIT : X, Y (both zero)
AUTO X,Y (OFFSET)	AOFS	<b>&lt;Execution of automatic offset setting&gt;</b> Command : AOFS Query : None
EXPAND	OEXP	<b>&lt;Setting and Query of display magnification&gt;</b> Command : OEXP 1, 0    Syntax: OEXP i, j Query : OEXP? 1    Syntax: OEXP? i    Response : 0 Range : i= 1 DATA1 (X,R)    j= 0    ×1 2 DATA2 (Y)               1    ×10 2    ×100 At INIT : X, Y (both ×1)

## i) RATIO display-related messages

Items	Header	Operation and setting range
RATIO ON	RAT	<b>&lt;Setting and Query of ratio display on/off&gt;</b> Command : RAT 1 Query : RAT?            Response : 1 Range : 0 off 1 on (ratio display) At INIT : off
RATIO K (SHIFT+)	KFAC	<b>&lt;Setting and Query of K-constant&gt;</b> Command : KFAC 0.25 Query : KFAC?            Response : 0.25 Range : 0.1000 to 1.9999 and 2.000 to 9.999 At INIT : 1.0000

## j) Messages of auxiliary output(AUX OUT1,AUX OUT2)

Items	Header	Operation and setting range
AUX OUT1 AUX OUT2	AUXV	<b>&lt;Setting and Query of auxiliary output(DC voltage)&gt;</b> Command : AUXV 1, 1.0    Syntax: AUXV i, x Query : AUXV? 1        Syntax: AUXV? i    Response : 1.000 Range : i = 1    AUX OUT1 2    AUX OUT2 x = voltage    -10.000 to +10.000 [V] At INIT : No change

## k) Setting memory(STORE,RECALL)-related Messages

Items	Header	Operation and setting range
STORE	*SAV	<b>&lt;Saving setup&gt;</b> Command : *SAV 1 Query : None Range : 1 to 9 At INIT : The contents of a setting memory do not change.
RECALL	*RCL	<b>&lt;Recall setup&gt;</b> Command : *RCL 1 Query : None Range : 1 to 9 and 0 (0: setup of power on) At INIT : Not recall



**m) Related messages of measurement data read-out (Not operated from a panel)**

Items	Header	Operation and setting range
OUTPUT TYPE	OTYP	<p><b>&lt;Setting and Query of the kind of measurement data to read&gt;</b></p> <p>Command : OTYP 1,2,3    Syntax : OTYP i {j,k,l,m,n}</p> <p>Query : OTYP?    Response : 1,2,3</p> <p>Range : i, j, k, l, m, n (respectively)</p> <p>0 line number</p> <p>1 DATA1 display value</p> <p>2 DATA2 display value</p> <p>3 FREQ (frequency of reference signal)</p> <p>4 SENSITIVITY</p> <p>5 OVERLEVEL</p> <p>The number of data is 1 to 6. It divides with a comma at the time of plurality. Two or more selections of the same parameter are possible. The order of parameter is arbitrary.</p> <p>At INIT : Not changed</p>
DATA OUTPUT	DOUT?	<p><b>&lt;Query of the newest measurement data&gt;</b></p> <p>Command : None</p> <p>Query : DOUT?</p> <p>Response : 1.2345E-06, -0.7890E-06, 1.0000E+03</p> <p>(It is outputted to the order chosen by OTYP.)</p> <p>Range : line number always 00000</p> <p>DATA1 display data of DATA1</p> <p>DATA2 display data of DATA2</p> <p>FREQ frequency of reference signal [Hz]</p> <p>(fundamental frequency at harmonic measurement)</p> <p>SENSITIVITY Response data of VSEN? or ISEN?</p> <p>(Dependent on a setup of a measurement signal input)</p> <p>OVERLEVEL Response data of OVCR?</p>
OUTPUT SAMPLING PERIOD	OSMP	<p><b>&lt;Setting and Query of continuation data output sampling period&gt;</b></p> <p>Command : OSMP 1.0</p> <p>Query : OSMP?    Response : 1.0</p> <p>Range : 0.1 to 10000.0 [s], Resolution 0.1 s</p> <p>At INIT : Not changed</p>
OUTPUT START	OSTR	<p><b>&lt;Directions of start and stop of a continuation data output, and inquiry of the state&gt;</b></p> <p>Command : OSTR 1</p> <p>Query : OSTR?    Response : 1</p> <p>Range : 0 Stop (under stop)</p> <p>1 Start (under output)</p> <p>After directing to start, if a trigger is performed, measurement data will be put on output cue with the set-up cycle.</p> <p>The value of the line number increases by one between 00000 to 99999. If maximum is exceeded, it will return to 00000.</p> <p>At INIT : Stop</p>

## n) Data memory-related messages (Cannot be operated from the panel)

1/3

Items	Header	Operation and setting range
DATA MEMORY TYPE	DTYP	<p><b>&lt;Setting and Query of the kind of data to record &gt;</b></p> <p>Command : DTYP 1</p> <p>Query : DTYP?            Response : 1</p> <p>Range : 0 DATA1 1 DATA2 2 DATA1,DATA2 3 DATA2,AUX IN2 4 DATA1,DATA2,FREQ 5 DATA1,DATA2,AUX IN1,AUX IN2 (Recorded by FREQ is 32 bits and the other is 16 bits)</p> <p>At INIT : Not changed</p>
DATA MEMORY SIZE	DSIZ	<p><b>&lt;Setting and Query of record length&gt;</b></p> <p>Command : DSIZ 1</p> <p>Query : DSIZ?            Response : 1</p> <p>Range : 0 2K            Record length describes by 1 4K            the number of data. 2 8K            of data. 3 16K           16 bit / data converted 4 32K           1K is 1024 bits. 5 64K           The total record length is divided                  into specified length.</p> <p>At INIT : Not changed</p>
DATA MEMORY NUMBER	DNUM	<p><b>&lt;Setting and Query of data memory number to record&gt;</b></p> <p>Command : DNUM 0</p> <p>Query : DNUM?            Response : 0</p> <p>Range : 0 to 31    From 0 to (divided number - 1) can be used.</p> <p>At INIT : Not changed</p>
DATA MEMORY SAMPLING PERIOD	DSMP	<p><b>&lt;Setting and Query of record sampling period&gt;</b></p> <p>Command : DSMP 5</p> <p>Query : DSMP?            Response : 5</p> <p>Range : 0 Trigger            10 50ms 1 0.0625ms            11 100ms 2 0.125ms            12 200ms 3 0.25ms            13 500ms 4 0.5ms            14 1s 5 1ms            15 2s 6 2ms            16 5s 7 5ms            17 10s 8 10ms            18 20s 9 20ms</p> <p>If a trigger is chosen, it is recorded for every trigger signal. When using TRIG of the rear panel, permission by the TENB command is required.</p> <p>At INIT : 1 ms</p>

## n) Data memory-related messages (Cannot be operated from the panel)

2/3

Items	Header	Operation and setting range
TRIGGER ENABLE	TENB	<b>&lt;Setting and Query of enable/disable of external trigger input TRIG IN &gt;</b> Command : TENB 1 Query : TENB?            Response : 1 Range : 0    Enable 1    Disable At INIT : Not changed
TRIGGER	*TRG	<b>&lt;Excecution of trigger&gt;</b> Command : *TRG    Recording start, or record 1sample Query : None
STORE START	STRT	<b>&lt;prepared recording start&gt;</b> Command : STRT Query : None After this, recording start by a trigger signal This command is ignored at the time under record.
STORE STOP	STOP	<b>&lt;Stop recording&gt;</b> Command : STOP Query : None Not under recording, this command is ignored.



## o) Messages of status system (Cannot be operated from the panel)

1/6

Items	Header	Operation and setting range
CLEAR STATUS	*CLS	<p><b>&lt;Clear status&gt;</b>  Command : *CLS  Query : None</p> <ul style="list-style-type: none"> <li>• The following registers are cleared. <ul style="list-style-type: none"> <li>Standard event status register</li> <li>Operation event register</li> <li>Over level event register</li> <li>Warning event register.</li> </ul> </li> <li>• Execution of *OPC or *OPC? command is cancelled.</li> <li>• Cleared error code queue</li> <li>• Not cleared enable registers</li> </ul>
POWER-ON STATUS CLEAR	*PSC	<p><b>&lt;Setting and Query of power on status clear flag&gt;</b>  Command : *PSC 1  Query : *PSC?      Response : 1  Range : At the setup -32767 to +32767</p> <p>When it is not 0, the following registers are cleared at power on.  In the case of 0, it does not clear.</p> <ul style="list-style-type: none"> <li>• Service request enable register</li> <li>• Standard event status enable register.</li> <li>• Operation event enable register</li> <li>• Over level event enable register</li> <li>• Warning event enable register.</li> </ul> <p>At Response : 0 or 1  0 will be returned if set as 0. 1 will be returned if set up except for 0.</p> <p>At INIT : Not changed</p>

**[The clearance of a status byte register]**

\*CLS command does not clear a status byte register directly. However, except for MAV bit and RQS bit, the bit of a status byte register is cleared indirectly.

The MAV bit of status byte register is indirectly clearable by clearing input buffer using device clear.

The RQS bit is clearable by serial-poll.

**o) Messages of status system (Cannot be operated from the panel)****2/6**

Items	Header	Operation and setting range
OPERATION COMPLETE	*OPC	<p><b>&lt;Reporting the end of operation&gt;</b>  Command : *OPC  When all processings of the overlap command under execution are completed, the OPC bit of a standard event status register is set.</p> <p>Query : *OPC?            Response : 1  "1" is returned when all processings of the overlap Command under execution are completed ("1" is put on output queue). Thereby, the MAV bit of a status byte register is set.  If it is going to receive the response to this query, it will be kept waiting until processing of an overlap command is completed.  When there is no overlap command under execution, an OPC bit is set or "1" is returned immediately.  Supplement: SRQ can be sent in OPC or MAV bit.  →Refer to "5.3 Service request and the status structure".</p>
WAIT TO CONTINUE	*WAI	<p><b>&lt;Until a command finishes performing, the succession command is made to stand by. &gt;</b>  Command : *WAI  Query : None  It is made to wait for execution of a succession command until all processings of the following command under execution are completed.</p>

**[Overlap Command]**

There are two kinds of commands. One side executes the following command, after processing is completed. Another side can start execution of the following command, before processing of a command is completed.

The command to start the execution of the next command during the processing is called an overlap command.

There is the following overlap command in the LI5640.

- Record in a data memory
- Automatic setting (AUTO SET)
- Automatic sensitivity setting

By commands other than these, after the execution finishes, the following command is executed. Such a command is called sequential command.

After ending execution of an overlap command, \*OPC, \*OPC?, or \*WAI Command is used to perform the following command or an query.

In order to make it operate correctly, please send \*OPC, \*OPC?, and \*WAI command after the last of a program message.

Recommend : Overlap command1; Overlap command2; \*OPC

Not recommend1 : Overlap command1; \*OPC; Overlap command2 terminator

Not recommend2 : Overlap command terminator \*OPC terminator

## o) Messages of status system(Cannot be operated from the panel)

3/6

Items	Header	Operation and setting range
STATUS BYTE	*STB?	<b>&lt;Query of status-byte register&gt;</b> Command : None Query : *STB? Response : 32 Range : The sum of weight about the set factor. (decimal) Weight Factor 1 Over level event 2 Warning event 8 Error occurring 16 Response : Message of output enable 32 Standard event status 64 Master summary status 128 Operation event At INIT : Not changed
SERVICE REQUEST ENABLE REGISTER	*SRE	<b>&lt;Setting and Query of the service request enable register&gt;</b> Command : *SRE 17 Query : *SRE? Response : 17 Range : The sum of weight about the factor to permit (decimal) Same as status byte register. At INIT : Not changed
STANDARD EVENT STATUS REGISTER	*ESR?	<b>&lt;Query of standard event status register&gt;</b> Command : None Query : *ESR? Response : 32 Range : The sum of weight of the set factor (decimal) Weight Factor 1 Completion of operation 4 Query error 8 Error peculiar to equipment 16 Execution error 32 Command error 128 Power supply on
STANDARD EVENT STATUS ENABLE REGISTER	*ESE	<b>&lt;Setting and Query of standard event status register&gt;</b> Command : *ESE 1 Query : *ESE? Response : 1 Range : The sum of weight about the set factor (decimal) The factor is the same as the standard event status byte register. At INIT : Not changed

## o) Messages of status system (Cannot be operated from the panel)

4/6

Items	Header	Operation and setting range
OPERATION CONDITION REGISTER	OPCR?	<b>&lt;Query of operation condition register&gt;</b> Command : None Query : OPCR?            Response : 16 Range : The sum of the weight about the set factor (decimal) Weight            Factor 16        Under the data memory record 256       Under the automatic setup 512       Under the automatic sensitivity setup At INIT : Although it does not act directly, since operation used as a factor is forced to terminate, it is set to 0.
OPERATION EVENT REGISTER	OPER?	<b>&lt;Query of operation event register&gt;</b> Command : None Query : OPER?            Response : 16 Range : The sum of the weight about the set factor (decimal) Weight            Factor 16        Record in a data memory is ended. 256       Automatic setup is ended. 512       Automatic sensitivity setup is ended. At INIT : Not changed
OPERATION EVENT ENABLE REGISTER	OPEE	<b>&lt;Setting and Query of operation event enable register&gt;</b> Command : OPEE 16 Query : OPEE?            Response : 16 Range : The sum of the weight about the factor to permit (decimal) A factor is the same as the operation event register. At INIT : Not changed

## o) Messages of status system (Cannot be operated from the panel)

5/6

Items	Header	Operation and setting range
WARNING CONDITION REGISTER	WRCR?	<b>&lt;Query of warning condition register&gt;</b> Command : None Query : WRCR?      Response : 1 Range : The sum total of the weight of the set factor(decimal) Weight      Factor 1   Not synchronize with a reference signal (UNLOCK lamp lit) 2   SOURCE is set as SIGNAL, and compared with frequency and attenuation slope(dB/oct.), since the time constant is too small, it cannot lock. At INIT : Although it does not act directly,condition may change with change of a setup.
WARNING EVENT REGISTER	WRER?	<b>&lt;Query of warning event register&gt;</b> Command : None Query : WRER?      Response : 1 Range : The sum of the weight about the set factor (decimal) Weight      Factor 1   Not synchronized with a reference signal 2   SOURCE is set as SIGNAL,and compared with frequency, since the time constant is too small, it cannot lock. At INIT : Not changed
WARNING EVENT ENABLE REGISTER	WREE	<b>&lt;Setting and Query of warning event register&gt;</b> Command : WREE 1 Query : WREE?      Response : 1 Range : The sum of the weight about the factor to permit (decimal) A factor is the same as the warning event register. At INIT : Not changed

## o) Messages of status system (Cannot be operated from the panel)

6/6

Items	Header	Operation and setting range
OVERLEVEL CONDITION REGISTER	OVCR?	<b>&lt;Query of over-level condition register&gt;</b> Command : None Query : OVCR? Response : 1 Range : The sum of the weight about the set factor (decimal) Weight Factor 1 Input over level 2 Middle stage over level 4 Over level of DATA1 display 8 Over level of DATA2 display 16 Over level of DATA1 ratio-display 32 Over level of DATA2 ratio-display At INIT : Although it does not act directly condition may change with change of a setup.
OVERLEVEL EVENT REGISTER	OVER?	<b>&lt;Query of over level event register&gt;</b> Command : None Query : OVER? Response : 1 Range : The sum of the weight about the set factor (decimal) Weight Factor 1 Input over-level occurred. 2 Middle stage over-level occurred. 4 DATA1 display over-level occurred. 8 The over level for DATA2 display occurred. 16 The over level for DATA1 ratio-display occurred. 32 The over level for DATA2 ratio-display occurred. At INIT : Not changed
OVERLEVEL EVENT ENABLE REGISTER	OVEE	<b>&lt;Setting and Query of over-level event enable register&gt;</b> Command : None Query : OVEE? Response : 1 Range : The sum of the weight about the factor to permit (decimal) A factor is the same as the warning event register. At INIT : Not changed
ERROR	EROR?	<b>&lt;Query of error code&gt;</b> Command : None Query : EROR? Response : -113, "Undefined header" Error number and error message are returned. Refer to "5.8 Error message of an external interface."

**p) Messages peculiar to other GPIB (Cannot be operated from the panel)**

Items	Header	Operation and setting range
RESET	*RST	<b>&lt;Execution of reset&gt;</b> Command : *RST Query : None <ul style="list-style-type: none"> <li>• Each setup is set as the state at the time of INIT execution.</li> <li>• Execution of the received command *OPC and *OPC? is cancelled.</li> <li>• Record in a data memory is ended.</li> <li>• All data memories are cleared.</li> </ul>
IDENTIFI- CATION	*IDN?	<b>&lt;Query of the maker, the model name, etc&gt;</b> Command : None Query : *IDN? Response: : The following strings are responded. "NF-ELECTRONIC-INSTRUMENTS,model name,serial number,version" After the model name changes with every device. ex.: "LI5640,1234567,1.00"
TEST	*TST?	<b>&lt;Query of self-check result&gt;</b> Command : None Query : *TST?      Response : 0 (0 is always returned.) Range : 0 With no abnormalities 1 With abnormalities

### 5.6.2 Program Message List (Compatible Message)

The compatible message is prepared for LI5640 so that the program created for the conventional model (5610B,5600A) can be corrected easily. Since the almost same description as the conventional program code can be used, it ends with the minimum correction. However, there is a functionally different portion with the conventional model and LI5640. For this reason, there is no perfect compatibility. When you do change work, please check all these tables beforehand.

The compatible message is not based on IEEE-488.2.

#### [The supplement about a table]

Items	Header	Operation and Data Range
	<p>The header of a command is shown when there is a command.</p> <p>The header of Query is shown when there is only Query.</p>	<p>&lt;Show the contents of operation&gt;</p> <p>Command : Show the example of command message</p> <p>Query : Show the example of query message</p> <p>Response : Show the example of response message</p> <p>Syntax : When it has two or more data by a setup or inquiry, how to locate data in a line is shown.</p> <p>Range : The range of data in a setup, an inquiry, or a response is shown.</p> <p>At INIT : The setup by the INIT is shown.</p>
		<p>A dotted line to the bottom is a new corresponding message. Only the outline is shown.</p> <p> For details ➔ Refer to "5.6.1 Program message list".</p>

- When there is a corresponding query message, it becomes header of command message that "?" is attached in front of the command message.
- When using two or more data, it divides with a comma ",".

## a) Compatible messages of reference system(REFERENCE)

1/2

Items	Header	Operation and Data Range
ADJUST PHASE	ADP	<b>&lt;Setting and Query of phase offset&gt;</b> Command : ADP 9000 (18000 is changed into -18000.) Query : ?ADP Response : 9000 Range : -18000 to +18000 (-180.00° to +180.00° equivalent) At INIT : 0
PHASE	PHAS	Command : PHAS 90.0 Query : PHAS? Response : 90.00 Range : -180.00 to +179.99 [°] (+180 is changed into -180)
AUTO FUNCTION PHASE SET	AUP	<b>&lt;Execution of automatic phase-offset setting&gt;</b> Command : AUP Query : None
PHASE-AUTO	APHS	Command : APHS Query : None
INT OSC FREQ	OFQ	<b>&lt;Setting and Query of frequency about internal oscillator&gt;</b> Command : OFQ 100,3 Syntax : OFQ i,j Query : ?OFQ Response : 100,3 Range : i = Oscillation frequency Range in the following ( ) j = Oscillation frequency range -2: 0.0005 to 0.1200Hz (5 to 1200) -1: .0010 to 1.2000Hz (1 to 1200) 0: .01 to 12.000Hz (1 to 1200) 1: .10 to 120.00Hz (1 to 1200) 2: .0010k to 1.2000kHz (1 to 1200) 3: .010k to 12.000kHz (1 to 1200) 4: .10k to 105.00kHz (1 to 1050) Since there is no range of oscillation frequency in the LI5640, therefore command and query are not necessarily the same. At INIT : Not changed
FREQ	FREQ	Command : FREQ 1E3 Query : FREQ? Response : 1.0000E+03 Range : 0.0005 Hz to 105.00 kHz It is used when having chosen INT OSC.
BASIC FUNCTION E RANGE	BFR	<b>&lt;Setting and Query of analysis frequency range&gt;</b> Command : BFR 1 (Since this function does not exist, only a range check performs it.) Command : ?BFR Response : 2 (2 is always returned.) Range : 0 0.5 to 12 Hz 1 10 to 120 Hz 2 100 to 1.2kHz 3 1k to 12kHz 4 10k to 200kHz
	None	

## a) Compatible message of reference system(REFERENCE)

2/2

Items	Header	Operation and Data Range
INT OSC LEVEL	OLV	<b>&lt;Setting and Query of amplitude&gt;</b> Command : OLV 100,1    Syntax : OLV i,j Query : ?OLV            Response : 100,1 Range : i = Oscillator output level 0 to 500 j = Oscillator output level range 0: 0.0 m to 50.0 mV 1: 0 m to 500 mV 2: 0.00 to 5.00 V  At INIT : Not changed
AMPTD	AMPL	Command : AMPL 0.1,1    Syntax : AMPL x, i Query : AMPL?            Response : 0.100,1 Range : x = Amplitude 0.0 m to 5.00 Vrms (within range) i = Amplitude range 0: 50mV, 1: 500 mV, 2: 5V
BASIC FUNCTION REF MODE	BRM	<b>&lt;Setting of reference signal&gt;</b> Command : BRM 2 Query : ?BRM            Response : 2 Range : 0 : INT OSC F    4 : SIGNAL F (no previous model) 1 : INT OSC 2F    5 : SIGNAL 2F (no previous model) 2 : REF IN F        6 : INT OSC (order>2, only response) 3 : REF IN 2F      7 : REF IN (order>2, only response) 8 : SIGNAL (order>2, only Response)  Operation by SIGNAL 2F is not guaranteed. In order to maintain compatibility in case of REF IN, it is set as SINE POS by the REDG command.  At INIT : Not changed
SOURCE	RSRC	<b>&lt;Setting and Query of reference signal source&gt;</b> Command : RSRC 0        Query : RSRC?        Response : 0 Range : 0 REF IN, 1 INT OSC, 2 SIGNAL
EDGE	REDG	<b>&lt;Setting and Query of reference signal synchronous edge&gt;</b> Command : REDG 0        Query : REDG?        Response : 0 Range : 0 SINE POS, 1 TTL POS, 2 TTL NEG
nF	HARM	<b>&lt;Setting and Query of harmonic order&gt;</b> Command : HARM 2        Query: HARM?        Response : 2 Range : 1 to 19999 (integer)

**b) Compatible messages of measured signal system (SIGNAL INPUT)**

Items	Header	Operation and setting range
	None	<b>&lt;Setting and Query of measured signal input &gt;</b> Set as A or A-B by the ISRC command.
SIGNAL	ISRC	Command : ISRC 0      Query : ISRC?      Response : 0 Range : 0 A, 1 A-B, 2 I(10 <sup>6</sup> ), 3 I(10 <sup>8</sup> )
	None	<b>&lt;Setting and Query of input coupling&gt;</b> Set as AC by the ICPL command.
COUPLING	ICPL	Command : ISRC 0      Query : ISRC?      Response : 0 Range : 0 AC, 1 DC
	None	<b>&lt;Setting and Query of measured sibnal ground&gt;</b> Set as FLOAT by IGNDC ommand.
GROUND	IGND	Command : IGND 0      Query : IGND?      Response : 0 Range : 0 FLOAT, 1 GROUND

In order to maintain compatibility, it is necessary to make it a setup shown in the table using the new command.

**c) Compatible messages of automatic setup (AUTO SET)**

Items	Header	Operation and Data Range
<u>A</u> UTO FUNCTION AUTO SET	AUS	<b>&lt;Excecution of automatic setup&gt;</b> Command : AUS 10 Query : None Range : Forced-termination time 0 to 9999 [s] (In the case of 0, it does not force to terminate.)
AUTO SET	ASET	Command : ASET      Query : None When sensitivity is not decided, it ends automatically.

## d) Filter(FILTER)-related compatible messages

Items	Header	Operation and Data Range
FILTER FREQ	FFQ	<p><b>&lt;Command of cut-off frequency&gt;</b>  Command : FFQ 123, 2      Syntax : FFQ i, j  (Since this function does not exist, it performs only the check of the range.)  Since this function does not exist, in order to remove noise and to secure dynamic reserve, the attenuation slope or the time-constant is enlarged.</p> <p>Query : ?FFQ      Response : 400,2(400,2 are always returned.)  Range : i = Cut-off frequency 100 to 1200  ( 5 to 1200 only at the time of i = 1)  j = Cut-off frequency range  1 0.5 to 120.0Hz    3 1k to 12.00kHz  2 100 to 1200Hz    4 10k to 120.0kHz</p>
	None	
FILTER MODE	FMO	<p><b>&lt;Setting and Query of filter&gt;</b>  Command : FMO 33 (Since this function does not exist, only a Range check performs it.)  Query : ?FMO      Response : 0 (THRU is always returned.)  Range : 0 THRU  1 HPF  2 LPF  30 Normal Q1    33 LPF Type Q1    36 HPF Type Q1  31 Normal Q5    34 LPF Type Q5    37 HPF Type Q5  32 Normal Q30    35 LPF Type Q30    38 HPF Type Q30</p>
	None	
AUTO FUNCTION AUTO TUNE	AUT	<p><b>&lt;Setting and Query of auto tune&gt;</b>  Command : AUT 0 (Since this function does not exist, only a range check performs it.)  Query : ?AUT      Response : 0 (zero is always returned.)  Range : 0 AUTO TUNE OFF, 1 AUTO TUNE ON</p>
	None	
	None	<p><b>&lt;Setting and Query of line frequency noise reduction filter&gt;</b>  Since this function is not in the conventional models, ILIN 0 is set up (Not used). When measurement frequency is separated from power supply frequency and its twice enough, it may use this filter.</p>
LINE LINE × 2	ILIN	<p>Command : ILIN 0      Query: ILIN?      Response : 0  Range : 0 Not used, 1 LINE, 2 LINE × 2,  3 LINE and LINE × 2</p>
	None	<p><b>&lt;Setting and Query of low-pass filter&gt;</b>  Since this function is not in the conventional models, ITHR 0 is set up (Used).</p>
LPF THRU	ITHR	<p>Command : ITHR 0      Query : ITHR?      Response : 0  Range : 0 Used, 1 Not used (LHP THRU lamp lit)</p>

## e) Dynamic reserve(DYNAMIC RESERVE)-related compatible messages

Items	Header	Operation and Data Range
BASIC FUNCTION DYN RES	BDR	<p><b>&lt;Setting and Query of dynamic reserve&gt;</b></p> <p>Command : BDR 1</p> <p>Query : ?BDR      Response : 1</p> <p>Range : 0 HIGH           1 MEDIUM           2 LOW</p> <p>At INIT : LOW</p> <p>The value (dB) of actual dynamic reserve is different even if it is the same setup when LI5640 is compared with a conventional model. Moreover, it differs also with setup of a filter or time constant.</p> <p>→Refer to <b>"4.5 Operation of dynamic reserve."</b></p>
DYNAMIC RESERVE	DRSV	<p>Command : DRSV 1      Query: DRSV?      Response : 1</p> <p>Range : 0 HIGH, 1 MEDIUM, 2 LOW</p>

## f) Sensitivity(SENSITIVITY)-related compatible messages

Items	Header	Operation and Data Range
BASIC FUNCTION SENSITIVITY	BSS	<p><b>&lt;Setting and Query of Sensitivity&gt;</b>  Command : BSS 10  Query : ?BSS Response: 10  Range: -5 5n V/fA 5 500μV/pA Only Response  -4 10 nV/fA 6 1 mV/nA 13 2 nV/--  -3 50 nV/fA 7 5 mV/nA 14 20 nV/fA  -2 100 nV/fA 8 10 mV/nA 15 200 nV/fA  -1 500 nV/fA 9 50 mV/nA 16 2 μV/pA  0 1 μV/pA 10 100 mV/nA 17 20 μV/pA  1 5 μV/pA 11 500 mV/nA 18 200 μV/pA  2 10 μV/pA 12 1 V/uA 19 2 mV/nA  3 50 μV/pA 20 20 mV/nA  4 100 μV/pA 21 200 mV/nA</p> <p>The conventional model is 1-3 sequence. For example, 5 mV are used when it is conventional 3 mV.  A unit is the order of voltage/current. When a signal input is A or A-B, it becomes an inquiry of voltage sensitivity.  It becomes an inquiry to a setup of current sensitivity at the time of I(10<sup>6</sup>) or I(10<sup>8</sup>). The setting range changes with selections or noise measurement of a signal input.</p> <p>At INIT : 1 V/μA</p>
SENSITIVITY	VSEN	<p><b>&lt;Setting and Query of Voltage Sensitivity&gt;</b>  Command : VSEN 23 Query: VSEN? Response: 23  Range : 0 2 nV to 26 1V (1-2-5 Sequence)</p>
	ISEN	<p><b>&lt;Setting and Query of Current Sensitivity&gt;</b>  Command : ISEN 23 Query: ISEN? Response: 23  Range : 1 5 fA to 26 1 μA (1-2-5 Sequence)  The setting range changes with differences in current to voltage conversion gain.</p>
AUTO FUNCTION AUTO RANGE	AUR	<p><b>&lt;Execution of Automatic Sensitivity Adjustment&gt;</b>  Command : AUR 1 (Nothing is carried out during execution.)  Query : ?AUR Response: 0 (Zero is always returned.)  Range: : 0 Off (No execution)  1 On (Execute automatic sensitivity adjustment)</p> <p>At INIT : Off</p>
AUTO (SENSITIVITY)	ASEN	<p>Command : ASEN Query : None</p>
SPECIAL FUNCTION LIMIT	SLM	<p><b>&lt;Setting and Query of the highest sensitivity restrictions at the auto-range-operation.&gt;</b>  Command : SLM 5 (Since this function does not exist, it performs only a range check.)  Query : ?SLM Response: 0 (Zero is always returned.)  Range : 0 1 μV/pA 7 5 mV/nA  1 5 μV/pA 8 10 mV/nA  2 10 μV/pA 9 50 mV/nA  3 50 μV/pA 10 100 mV/nA  4 100 μV/pA 11 500 mV/nA  5 500 μV/pA 12 1 V/μA  6 1 mV/nA 13 OFF</p>
	None	

## g) Time Constant(TIME CONSTANT) and Averaging-related compatible messages

Items	Header	Operation and Data Range
BASIC FUNCTION T CONST	BTC	<b>&lt;Setting and Query of Time Constant&gt;</b> Command : BTC 5 Query : ?BTC Response: 5 Range : -4 10 $\mu$ s 0 1 ms 10 100 s -3 30 $\mu$ s 1 3 ms 11 300 s -2 100 $\mu$ s 2 10 ms 12 1 ks -1 300 $\mu$ s 3 30 ms 13 3 ks 4 100 ms 14 10 ks 5 300 ms 15 30 ks 6 1 s 7 3 s 8 10 s 9 30 s At INIT : 100 ms (1ms to 30 s for conventional model)
TIME CONSTANT	TCON	Command : TCON 9 Query: TCON? Response: 9 Range : 0 10 $\mu$ s to 19 30 ks
BASIC FUNCTION dB/OCT	BDO	<b>&lt;Setting and Query of Attenuation slope &gt;</b> Command : BDO 1 Query : ?BDO Response: 1 Range : 0 6 dB/oct 1 12 dB/oct 2 18 dB/oct 3 24 dB/oct At INIT : 24 dB/oct ( 0 and 1 for conventional model )
SLOPE	SLOP	Command : SLOP 1 Query: SLOP? Response: 1 Range: 0 6 dB/oct, 1 12 dB/oct, 2 18 dB/oct, 3 24 dB/oct
	None	<b>&lt;Setting and Query of synchronous filter on/off &gt;</b> Since this function does not exist, it sets a SYNC 0.(Normal filter)
SYNC	SYNC	Command : SYNC 0 Query: SYNC? Response: 0 Range : 0 Off (Normal filter), 1 On (synchronous filter)
AVERAGE TIMES	AVT	<b>&lt;Setting and Query of averaging times (n of the 2<sup>n</sup>) &gt;</b> Command : AVT 5 (Since this function does not exist, it performs only a range check.) Query : ?AVT Response: 6 (6 is always returned.) Range : 0 to 9
	None	
AVERAGE MODE	AVM	<b>&lt;Setting and Query of averaging mode&gt;</b> Command : AVM 1 (Since averaging function does not exist, it performs only a range check.) Query : ?AVM Response: 0 (Zero is always returned.) Range : 0 No averaging, 1 LIN, 2 EXP
	None	



## h) Measurement data display(DATA1,DATA2)-related compatible messages

2/3

Items	Header	Operation and Data Range																																																									
NORMALIZE MODE	NMO	<b>&lt;Setting and Query of normalizing measurement&gt;</b> Command : NMO 1 Query : ?NMO Response: 1 Range : -1 Off (Normal display) 0 dB 1 % At INIT : Off																																																									
NORMALIZE	NORM	Command : NORM 1 Query: NORM? Response: 1 Range : 0 Off, 1 dB, 2 %																																																									
NORMALIZE VALUE	NVL	<b>&lt;Setting and Query of normalizing standard&gt;</b> Command : NVL 512, 4 Syntax: NVL i, j Query : ?NVL Response: 512,4 Range : i = Standard value, Range in the following parenthesis j = Range of standard value <table style="margin-left: 40px;"> <thead> <tr> <th>j</th> <th>Range</th> <th>Standard value</th> </tr> </thead> <tbody> <tr><td>-5</td><td>5 nV/fA 1.000 to 9.999</td><td>(1000 to 9999)</td></tr> <tr><td>-4</td><td>10 nV/fA 1.000 to 99.990</td><td>(100 to 9999)</td></tr> <tr><td>-3</td><td>50 nV/fA 1.00 to 99.99</td><td>(100 to 9999)</td></tr> <tr><td>-2</td><td>100 nV/fA 1.00 to 999.90</td><td>(10 to 9999)</td></tr> <tr><td>-1</td><td>500 nV/fA 1.0 to 999.9</td><td>(10 to 9999)</td></tr> <tr><td>0</td><td>1 μV/pA 0.0010 to 9.9990</td><td>(1 to 9999)</td></tr> <tr><td>1</td><td>5 μV/pA 0.001 to 9.999</td><td>(1 to 9999)</td></tr> <tr><td>2</td><td>10 μV/pA 0.010 to 99.990</td><td>(1 to 9999)</td></tr> <tr><td>3</td><td>50 μV/pA 0.01 to 99.99</td><td>(1 to 9999)</td></tr> <tr><td>4</td><td>100 μV/pA 0.10 to 999.90</td><td>(1 to 9999)</td></tr> <tr><td>5</td><td>500 μV/pA 0.1 to 999.9</td><td>(1 to 9999)</td></tr> <tr><td>6</td><td>1 mV/nA 0.0010 to 9.9990</td><td>(1 to 9999)</td></tr> <tr><td>7</td><td>5 mV/nA 0.001 to 9.999</td><td>(1 to 9999)</td></tr> <tr><td>8</td><td>10 mV/nA 0.010 to 99.990</td><td>(1 to 9999)</td></tr> <tr><td>9</td><td>50 mV/nA 0.01 to 99.99</td><td>(1 to 9999)</td></tr> <tr><td>10</td><td>100 mV/nA 0.10 to 999.90</td><td>(1 to 9999)</td></tr> <tr><td>11</td><td>500 mV/nA 0.1 to 999.9</td><td>(1 to 9999)</td></tr> <tr><td>12</td><td>1 V/uA 0.0010 to 1.0000</td><td>(1 to 1000)</td></tr> </tbody> </table> At INIT : 1000, 1 V/μA	j	Range	Standard value	-5	5 nV/fA 1.000 to 9.999	(1000 to 9999)	-4	10 nV/fA 1.000 to 99.990	(100 to 9999)	-3	50 nV/fA 1.00 to 99.99	(100 to 9999)	-2	100 nV/fA 1.00 to 999.90	(10 to 9999)	-1	500 nV/fA 1.0 to 999.9	(10 to 9999)	0	1 μV/pA 0.0010 to 9.9990	(1 to 9999)	1	5 μV/pA 0.001 to 9.999	(1 to 9999)	2	10 μV/pA 0.010 to 99.990	(1 to 9999)	3	50 μV/pA 0.01 to 99.99	(1 to 9999)	4	100 μV/pA 0.10 to 999.90	(1 to 9999)	5	500 μV/pA 0.1 to 999.9	(1 to 9999)	6	1 mV/nA 0.0010 to 9.9990	(1 to 9999)	7	5 mV/nA 0.001 to 9.999	(1 to 9999)	8	10 mV/nA 0.010 to 99.990	(1 to 9999)	9	50 mV/nA 0.01 to 99.99	(1 to 9999)	10	100 mV/nA 0.10 to 999.90	(1 to 9999)	11	500 mV/nA 0.1 to 999.9	(1 to 9999)	12	1 V/uA 0.0010 to 1.0000	(1 to 1000)
j	Range	Standard value																																																									
-5	5 nV/fA 1.000 to 9.999	(1000 to 9999)																																																									
-4	10 nV/fA 1.000 to 99.990	(100 to 9999)																																																									
-3	50 nV/fA 1.00 to 99.99	(100 to 9999)																																																									
-2	100 nV/fA 1.00 to 999.90	(10 to 9999)																																																									
-1	500 nV/fA 1.0 to 999.9	(10 to 9999)																																																									
0	1 μV/pA 0.0010 to 9.9990	(1 to 9999)																																																									
1	5 μV/pA 0.001 to 9.999	(1 to 9999)																																																									
2	10 μV/pA 0.010 to 99.990	(1 to 9999)																																																									
3	50 μV/pA 0.01 to 99.99	(1 to 9999)																																																									
4	100 μV/pA 0.10 to 999.90	(1 to 9999)																																																									
5	500 μV/pA 0.1 to 999.9	(1 to 9999)																																																									
6	1 mV/nA 0.0010 to 9.9990	(1 to 9999)																																																									
7	5 mV/nA 0.001 to 9.999	(1 to 9999)																																																									
8	10 mV/nA 0.010 to 99.990	(1 to 9999)																																																									
9	50 mV/nA 0.01 to 99.99	(1 to 9999)																																																									
10	100 mV/nA 0.10 to 999.90	(1 to 9999)																																																									
11	500 mV/nA 0.1 to 999.9	(1 to 9999)																																																									
12	1 V/uA 0.0010 to 1.0000	(1 to 1000)																																																									
STD	VSTD (Voltage)	Command : VSTD 51.2E-6 Query: VSTD? Response: 51.20E-6 Range : 1.0000 nV to 1.0000 V (In measurement of noise density, it differs. )																																																									
	ISTD (Current)	Command : ISTD 51.2E-12 Query: ISTD? Response: 51.20E-12 Range : 1.0000 fA to 1.0000 μA (It varies in the gain of the current-voltage conversion and so on. )																																																									

## h) Measurement data display(DATA1,DATA2)-related compatible messages

3/3

Items	Header	Operation and Data Range
ADJUST OFFSET	ADO	<p><b>&lt;Setting and Query of X offset value&gt;</b>  Command : ADO -316  Query : ?ADO Response: -316  Range : -5000 to +5000  100% of a sensitivity full scale corresponds to 1000 at the time of <math>1 \times 10^n</math>. And it corresponds to 2000 at the time of <math>2 \times 10^n</math>, and corresponds to 5000 at the time of <math>5 \times 10^n</math>.  X offset is set as ON.  It is not turned off even if it sets it as zero after this.  The same setup can be performed by OFSO and OFFS commands.  If Y offset is turned OFF, about X, it will be compatibility mostly with the conventional model.  R independent offset cannot be set up.  At INIT : 0</p>
X OFFSET Y OFFSET	OFFS	<p><b>&lt;Offset value&gt;</b>  Command : OFFS 1,10.0 Query: OFFS? 1 Response: 10.00  Range : The first number = 1 X, 2 Y  The second value = Offset value -100.00 to +100.00 [%]  The value of a sensitivity full scale is made into 100%.</p>
X OFFSET ON Y OFFSET ON	OFSO	<p><b>&lt;Offset ON/OFF&gt;</b>  Command : OFSO 1,1 Query: OFSO? 1 Response: 1  Range : The first number 1 X, 2 Y  The second number 0 Off, 1 On</p>
AUTO X,Y (OFFSET)	None AOFS	<p><b>&lt;Execution of automatic offset setting&gt;</b>  Command : AOFS Query: None  Offset is set up so that the value of X and Y may become zero.</p>
METER MAG X	MMX	<p><b>&lt;Setting and Query of X meter sensitivity(X and R of DATA1)&gt;</b>  Command : MMX 1  Query : ?MMX Response: 1  Range : <math>0 \times 1</math>, <math>1 \times 10</math>, <math>2 \times 100</math>  At INIT : <math>\times 1</math></p>
METER MAG Y	MMY	<p><b>&lt;Setting and Query of Y meter sensitivity(Y of DATA2 )&gt;</b>  Command : MMY 1  Query : ?MMY Response: 1  Range : <math>0 \times 1</math>, <math>1 \times 10</math>, <math>2 \times 100</math>  At INIT : <math>\times 1</math></p>
EXPAND	OEXP	<p><b>&lt;Expansion of the display&gt;</b>  Command : OEXP 1,0 Query:OEXP? 1 Response: 0  Range : The first number 1 DATA1(X,R), 2 DATA2(Y)  The second number <math>0 \times 1</math>, <math>1 \times 10</math>, <math>2 \times 100</math></p>

**i) Ratio display(RATIO)-related compatible messages**

Items	Header	Operation and Data Range
	None	<b>&lt;Setting and Query of ratio display ON/OFF&gt;</b>
RATIO ON	RAT	Command : RAT 1      Query: RAT?      Response: 1 Range : 0 Off, 1 On (Ratio display)
RATIO K	RAK	<b>&lt;Setting and Query of K-constant&gt;</b> Command : RAK 0.25 Query : ?RAK      Response: 0.25 Range : 0.1000 to 1.9999 (Resolution 0.0001) 2.000 to 9.999 (Resolution 0.001) At INIT : 1.0000
RATIO K (SHIFT+)	KFAC	Command : KFAC 0.25      Query: KFAC?      Response: 0.25 Range : 0.1000 to 1.9999 and 2.000 to 9.999

**j) Compatible messages of auxiliary output(AUX OUT1, AUX OUT2)**

Items	Header	Operation and Data Range
	None	<b>&lt;Setting and Query of auxiliary output(DC voltage) &gt;</b>
AUX OUT1 AUX OUT2	AUXV	Command : AUXV 1,1.0      Syntax: AUXV i,x Query : AUXV? 1      Syntax: AUXV? i      Response: 1.000 Range : i=1 AUX OUT1, 2 AUX OUT2 x = Voltage - 0.000 to +10.000 [V]

**k) Setting memory(STORE,RECALL)-related compatible messages**

Items	Header	Operation and Data Range
	None	<b>&lt;Storing settings&gt;</b>
STORE	*SAV	Command : *SAV 1      Query: None Range : 1 to 9
	None	<b>&lt;Recalling settings&gt;</b>
RECALL	*RCL	Command : *RCL 1      Query: None Range : 1 to 9 and 0 (When power is turned on, the value is 0.)

## I ) Other pannel operation-related compatible messages

1/2

Items	Header	Operation and Data Range
SPECIAL FUNCTION INITIALIZE	SIN	<b>&lt;Change into initially set statuses&gt;</b> Command : SIN Query : None
INITIALIZE	INIT	Command : INIT                      Query: None
SPECIAL FUNCTION LAMP	SLP	<b>&lt;Setting and Query of lamp&gt;</b> Command : SLP 0 Query : ?SLP                      Response: 0 Range : 0 Off (all unlit),      1 On At INIT : No change
LAMP	LAMP	Command : LAMP 0      Query: LAMP?      Response: 0 Range : 0 Off (all unlit),      1 On





**m) Measurement data reading-related compatible messages (Can't be operated from a panel.) 2/2**

Items	Header	Operation and Data Range												
SPECIAL FUNCTION SAMPLING	SSA	<p><b>&lt;Setting and Query of the data transfer interval and the measurement processing interval&gt;</b></p> <p>Command : SSA 4, 1      Syntax: SSA i, j  Query : ?SSA      Response: 4,1  Range : i = Data transfer interval(n of the 2<sup>n</sup>) 0 to 16  j = Measurement processing interval</p> <table style="margin-left: 40px;"> <tr> <td>0</td> <td>Stop</td> <td>3</td> <td>1s</td> </tr> <tr> <td>1</td> <td>100ms</td> <td>4</td> <td>3s</td> </tr> <tr> <td>2</td> <td>300ms</td> <td>5</td> <td>10s</td> </tr> </table> <p>It is output in the time interval by 2<sup>i</sup> of the measurement processing interval.</p> <p>At INIT : No change</p>	0	Stop	3	1s	1	100ms	4	3s	2	300ms	5	10s
0	Stop	3	1s											
1	100ms	4	3s											
2	300ms	5	10s											
OUTPUT SAMPLING PERIOD	OSMP	<p><b>&lt;Setting and Query of continuous data output sampling period &gt;</b></p> <p>Command : OSMP 1.0      Query: OSMP?      Response: 1.0  Range : 0.1 to 10000.0[s],      Resolution 0.1 s</p>												
OUTPUT START/STOP	OSS	<p><b>&lt;Setting and Query about start/stop of measurement data output &gt;</b></p> <p>Command : OSS 1  Query : ?OSS      Response: 1  Range : 0 Stop  1 Start (On output)</p> <p>When a trigger is carried out after the start, measurement data are put in the interval set up with a SSA command in the output queue.  The line number increases every 1 from 00000.  A line number is returned to 00000 when it exceeds 99999.  Even if it turns ON the header of output data (HDR1), the header is not attached to this output.</p> <p>At INIT : Stop</p>												
OUTPUT START	OSTR	<p><b>&lt;Directions for the start, stop of the continuous data output &gt;</b></p> <p>Command : OSTR 1      Query: OSTR?      Response: 1  Range : 0 Stop (On stop), 1 Start (On output)</p> <p>When a trigger is executed after the start, measurement data are put in the output queue in the period set up with an OSMP command.</p>												

**n) The data memory-related compatible message (it cannot be operated from panel)**

Since there is no data memory in conventional model, there is no compatible message. Please use "5.6.1 Program message list n data memory-related message." The following is an extract.

Items	Header	Operation and setting range
DATA MEMORY TYPE	DTYP	<b>&lt;Setting and Query of the kind of recording data.&gt;</b> Command : DTYP 1 Query: DTYP? Response : 1 Range : 0 DATA1, 1 DATA 2, 2 DATA1, DATA2 3 DATA2, AUX IN 2, 4 DATA1, DATA2, FREQ, 5 DATA1, DATA2, AUX IN1, AUX IN2 FREQ is recorded by 32 bits and others are recorded by 16 bits
DATA MEMORY SIZE	DSIZ	<b>&lt;Setting and Query of the record length.&gt;</b> Command : DSIZ 1 Query: DSIZ? Response : 1 Range : 0 to 5 (corresponding with 2K to 64K data. 16bits/ data conversion)
DATA MEMORY NUMBER	DNUM	<b>&lt;Setting and Query of the number of recording data memory&gt;</b> Command : DNUM 0 Query: DNUM? Response : 0 Range : 0 to 31. Can be used from 0 (division number – 1).
DATA MEMORY SAMPLING PERIOD	DSMP	<b>&lt;Setting and Query of a record sampling cycle&gt;</b> Command : DSMP 5 Query: DSMP? Response : 5 Range : 0 to 18 (Corresponding with a trigger 0.0625ms to 20s)
TRIGGER ENABLE	TENB	<b>&lt;Setting and Query for permission/prohibition of the external trigger input TRIG IN.&gt;</b> Command : TENB 1 Query: TENB? Response : 1 Range : 0 Prohibition, 1 Permission
TRIGGER	*TRG	<b>&lt;Execution of a trigger (start of record, or 1 sample record) &gt;</b> Command : *TRG Query: None
STORE START	STRT	<b>&lt;A record start is prepared.&gt;</b> Command : STRT Query: None A trigger is performed in order to actually start record.
STORE STOP	STOP	<b>&lt;Record is stopped.&gt;</b> Command : STOP Query: None
STORED POINTS	SPTS?	<b>&lt;Query for times of a sampling &gt;</b> Command : None Query: SPTS? Response : 1024 Range : 0~65536
READ DATA MEMORY ASCII	DASC?	<b>&lt;Query of the recorded data (ASCII) &gt;</b> Command : None Query: DASC? 0, 256 Syntax : DASC? i, j Range : i = Read-out start position 0 to (The number of times of a record sampling – 1) j = The number of samples to read, The number of times of record sampling ( from 0). Response : Output data (16 bits and 32 bits) by Decimal character.
READ DATA MEMORY BINARY	DBIN?	<b>&lt;Query of the recorded data (binary) &gt;</b> Command : None Query: DBIN? 0, 256 Syntax : DBIN? i, j Range : Same as ASCII Response : Output data (16 bits and 32 bits) by the binary. Within 1 word, it outputs sequentially from a high-order byte

**o) The compatible message of a status system (it cannot be operated from a panel) 1/4**

Items	Header	Operation and Data Range
	None	<p><b>&lt;Status is cleared.&gt;</b>                      In order to maintain compatibility, it clears by the beginning of a program.</p>
CLEAR STATUS	*CLS	<p>Command : *CLS      Query: None</p> <ul style="list-style-type: none"> <li>● Clear the following registers.                             <ul style="list-style-type: none"> <li>Standard event status register</li> <li>Operation event register</li> <li>Over level event register</li> <li>Warning event register</li> </ul> </li> <li>● Cancellation of *OPC or *OPC? command.</li> <li>● Clearing for error code queue</li> </ul>
POWER-ON STATUS CLEAR	*PSC	<p><b>&lt;Setting and Query of a power on status clear flag.&gt;</b>                      *PSC 1 is set up in order to maintain compatibility.</p> <p>Command : *PSC 1      Query: *PSC?      Response : 1</p> <p>Range : -32767 to +32767</p> <p>When it is not 0, the following registers are cleared at the time of a power supply on.</p> <ul style="list-style-type: none"> <li>● Service request enable register</li> <li>● Standard event status enable register</li> <li>● Operation event enable register</li> <li>● Over level event enable register</li> <li>● Warning event enable register</li> </ul>
OPERATION COMPLETE	*OPC	<p><b>&lt;An end of operation is made to report.&gt;</b></p> <p>Command : *OPC      Query: *OPC?      Response : 1</p> <p>When the next operation is completed, the OPC bit of a standard event status register is set, or 1 is returned.</p> <ul style="list-style-type: none"> <li>● Record in a data memory</li> <li>● Automatic setting (AUTO SET)</li> <li>● Automatic sensitivity setting</li> </ul>
WAIT TO CONTINUE	*WAI	<p><b>&lt;It is made to wait for a succession command until a command finishes performing.&gt;</b></p> <p>Command : *WAI      Query: None</p> <p>It is made to wait for execution of a succession command until the following operation is completed.</p> <ul style="list-style-type: none"> <li>● Record in a data memory</li> <li>● Automatic setting (AUTO SET)</li> <li>● Automatic sensitivity setting</li> </ul>

## o) Compatible message of a status system (it cannot be operated from a panel) 2/4

Items	Header	Operation and Data Range
STATUS	?STS	<b>&lt;Query of status byte register&gt;</b> Command : None Query : ?STS Response: 17 Range : The sum of the weight of the set factor.(decimal) Weight Factor 1 Over level event 2 Warning event 8 Error generating 16 A response message output is possible. 32 Standard event status 64 Master status summary 128 Operation event At INIT : Not changed
STATUS BYTE	*STB?	Command : None Query: *STB? Response : 17
SRQ MASK	SRQ	<b>&lt;Setting and Query of service request enable register&gt;</b> Command : SRQ 17 Query : ?SRQ Response : 17 Range : The sum of the weight of the factor to permit.(decimal) Factor is the same as a status byte register. At INIT : Not changed
SERVICE REQUEST ENABLE REGISTER	*SRE	Command : *SRE 17 Query: *SRE? Response : 17
STANDARD EVENT STATUS REGISTER	None *ESR?	<b>&lt;Query of a standard event status register&gt;</b> Command : None Query: *ESR? Response : 32 Range : The sum of the weight of the set factor.(decimal) Weight Factor Weight Factor 1 Completion of operation      16 Execution error 4 Query error                    32 Command error 8 Inherent error of the equipment 128 Power on
STANDARD EVENT STATUS ENABLE REGISTER	None *ESE	<b>&lt;Setting and Query of a standard event status enable register.&gt;</b> Command : *ESE 1 Query: *ESE? Response : 1 Range : The sum of the weight of the factor to permit.(decimal) Factor is the same as a standard event status register.

**o) Compatible message of a status system (it cannot be operated from a panel) 3/4**

Items	Header	Operation and Data Range
OPERATION CONDITION REGISTER	None OPCR?	<b>&lt;Query of an operation condition register&gt;</b> Command : None      Query: OPCR?      Response : 16 Range : The sum of the weight of the set factor. (decimal) Weight      Factor 16      Under data memory record 256      During automatic setting 512      During automatic sensitivity setting at INIT : Although it does not act directly, since operation used as a factor is forced to terminate, it is set to 0.
OPERATION EVENT REGISTER	None OPER?	<b>&lt;Query of an operation event register&gt;</b> Command : None      Query: OPER?      Response : 16 Range : The sum of the weight of the set factor. (decimal) When the bit of a condition register is reset, the bit to which an event register corresponds is set.
OPERATION EVENT ENABLE REGISTER	None OPEE	<b>&lt;Setting and Query of an operation event enable register &gt;</b> Command : OPEE 16      Query: OPEE?      Response : 16 Range : The sum of the weight of the factor to permit. (decimal) A factor is the same as an operation event register.
WARNING CONDITION REGISTER	None WRCR?	<b>&lt;Query of a warning condition register&gt;</b> Command :None      Query: WRCR?      Response : 1 Range : The sum of the weight of the set factor. (decimal) Weight      Factor 1      It does not synchronize with a reference signal. 2      As SOURCE is set to SIGNAL, it is impossible to lock for which the time constant is too small under comparing with frequency and roll-off. At INIT : Although it does not act directly, condition may change with change of setting.
WARNING EVENT REGISTER	None WRER?	<b>&lt;Query of a warning event register&gt;</b> Command :None      Query: WRER?      Response : 1 Range : The sum of the weight of the set factor. (decimal) When the bit of a condition register is set, the bit to which an event register corresponds is set.
WARNING EVENT ENABLE REGISTER	None WREE	<b>&lt;Setting and Query of a warning event enable register&gt;</b> Command : WREE 1      Query: WREE?      Response : 1 Range : The sum of the weight of the factor to permit.(decimal) A factor is the same as a warning event register.

## o) Compatible message of a status system (it cannot be operated from a panel) 4/4

Items	Header	Operation and Data Range
OVER LEVEL	OVR	<b>&lt;Query of an over level condition register&gt;</b> Command : None Query : ?OVR Response: 1 Range : The sum of the weight of the set factor. (decimal) Weight Factor 1 Input over level 2 Middle stage over level 4 DATA1 display over level 8 DATA2 display over level 16 DATA1 ratio display over level 32 DATA2 ratio display over level The contents differ from the conventional model. At INIT : Although it does not act directly, condition may change with change of setting.
OVERLEVEL CONDITION REGISTER	OVCR?	Command : None Query: OVCR? Response : 1
OVERLEVEL EVENT REGISTER	None OVER?	<b>&lt;Query of over level event register&gt;</b> Command : None Query: OVER? Response : 1 Range : The sum of weight of set factor. (decimal) When the bit of a condition register is set, the corresponding bit of the event register is set. .
OVERLEVEL EVENT ENABLE REGISTER	None OVEE	<b>&lt;Setting and Query of over level event register&gt;</b> Command : None Query: OVEE? Response : 1 Range : The sum of weight of factor to permit. (decimal) Factor is the same as over level event register.
ERROR	?ERR	<b>&lt;Query of error code&gt;</b> Command : None Query : ?ERR Response : -113 (An error number is returned.)  Refer to <b>"5.8 Error message of an external interface."</b> At INIT : No change.
ERROR	EROR?	Command : None Query: EROR? Response : Error number. and error message



## 5.7 Standard execution time

Here, time to start processing of a program message is shown. Time to start transmission of a program message is included in this time.

Since time to actually start changes with the computer to be used, a GPIB interface board, a programming language, and driver software, the value shown here is a reference value.

### a) Use devices

Computer	: PC 386 SR / Seiko Epson
Language	: N88BASIC / NEC
Interface board	: PC-9801-29N / NEC

### b) Specific command and query

INIT(SIN)	: approx. 90 ms	The inside of ( ) is a compatible message.
*RST	: approx. 90 ms	
*RCL	: approx. 90 ms	
ASET (AUS)	: approx. 200 ms	The inside of ( ) is a compatible message.
DBIN?	: approx. 15 ms	

### c) Other commands and queries (except the above)

Command	: approx. 60 ms
Query	: approx. 30 ms

Although it changes with the contents of response, or states of apparatus of operation, if time for listeners to receive a response message is included in the case of a query, it will become long for about 10 ms.

**d) Data read-out from a data memory**

The data transmission time when querying and reading the data recorded on the data memory becomes the following value.

Approx. 30 s / 2Kdata (ASCII)

Approx. 0.5 s / 2Kdata (Binary)

However, the program and apparatus that were used are as follows.

- Program : Example of the following in "5.13 GPIB sample program"
  - " d ) Recording and reading to data memory (ASCII)"
  - " f ) Recording and reading to data memory (binary)"
- Computer : Venturis fx2(Pentium II 200 MHz) (DEC)
- OS : Windows 95 (Microsoft)
- Language : Visual Basic 5 (Microsoft)
- Interface board : PCI-488(PCI) (National Instruments)

Compared with ASCII, a binary is very high-speed. For this reason, it is convenient when handling a lot of data.

## 5.8 Error message of external interface

If an error occurs while carrying out external control by GPIB or RS-232, an error number will be displayed on a REFERENCE number display for several seconds.

Example : E - 1 0 3

If query message EROR? is used, this error number and a more detailed error message can be checked. The format of a response message is as follows.

Error No., error message      Example : -103, "Invalid separator"

**Table 5-7 Error message list of external interfaces (part 1)**

Error No.	Error message	Description
0	No error	There is no error.
-101	Invalid character	There is an invalid character in the receiving character sequence. Example : #
-103	Invalid separator	There is an invalid separator in the receiving character sequence. Example : AMPL 1.0 2 (The punctuation mark which must be a comma is a space)
-108	Parameter not allowed	There is too many data after header.
-109	Missing parameter	The number of the data after header is insufficient.
-112	Program mnemonic too long	There is a header that exceeds twelve characters in the receiving character sequence.
-113	Undefined header	There is an invalid header in the receiving character sequence.
-120	Numeric data error	Numeric data error. Example: 1.0E-555 (an index part is too large)
-121	Invalid character in number	There is an invalid character to the indication of the numerical value data.
-211	Trigger ignored	Since it was not ready for starting a continuation data output, the trigger was ignored. After a start is prepared, send the command of a trigger.
-221	Settings conflict	The specified setting couldn't be carried out because of the setting and conditions at that time.
	Settings conflict; auto time constant has not been accepted	An automatic time constant setting can't do because UNLOCK, or frequency is out of range, or reference signal is SIGNAL, or DATA1 display is NOISE.
	Settings conflict; auto set has not been accepted	An automatic setting can't do because UNLOCK, or frequency is out of range, or reference signal is SIGNAL.
	Settings conflict; auto phase has not been accepted	An automatic phase setting wasn't made because UNLOCK or a phase couldn't be measured.
	Settings conflict; offset auto X,Y has not been accepted	An automatic offset setting couldn't be done because UNLOCK or X or Y couldn't be measured.

Table 5-7 Error message list of external interfaces (part2)

Error No.	Error message	Description
-222	Data out of range	Command data following header are outside possible range with setting.
	Data out of range; memory	Command data related to the setting memory are outside possible range with setting.
	Data out of range; aux output	The command data of the auxiliary output are outside possible range with setting.
	Data out of range; auto set	Command data related to automatic setting are outside possible Range with setting.
	Data out of range; ratio	Command data related to RATIO are outside possible range with setting.
	Data out of range; data1	Command data related to DATA1 are outside possible range with setting.
	Data out of range; data2	Command data related to DATA2 are outside possible range with setting.
	Data out of range; reference	Command data related to the reference are outside possible Range with Setting.
	Data out of range; signal input	Command data related to the signal input are outside possible range with setting.
	Data out of range; filter	Command data related to the filter are outside possible range with setting.
	Data out of range; dynamic reserve	Command data related to the dynamic reserve are outside possible range with setting.
	Data out of range; sensitivity	Command data related to the sensitivity are outside possible range with setting.
	Data out of range; time constant	Command data related to the time constant are outside possible range with setting.
	Data out of range; data memory	Command data related to the data memory are outside possible range with setting.
	Data out of range; data output	Command data related to the data output are outside possible range with setting.
Data out of range; others	Command data except for the above are outside possible range with setting.	
-350	Queue overflow	Previous error code was destroyed not to finish going into the error code queue though an error occurred. (maximum 20 error code) Begin to read it, or clear it with a *CLS command before being full.
-410	Query INTERRUPTED	An output queue was cleared because the next program code was received before finishing the output of the response message for query message. Send the next program message after you receive response when you query.
-420	Query UNTERMINATED	There is no response message to output though it was specified a talker. Specify it in talker after you query.
-430	Query DEADLOCKED	Since response to query message exceeded 1024 characters, Response after it was destroyed.
-440	Query UNTERMINATED after indefinite response	“*IDN?”, “DASC?” or “DBIN?” should be the last query in the program message. Other query can't be sent until that is stopped after continuous data output is actually started with a *TRG command.

**Table 5-7 Error message list of external interfaces (part3)**

Error No.	Error message	Description
511	RS-232 framing error	Framing error occurred. Confirm that setting of baud rate, the data bit length and the parity are right.
512	RS-232 overrun error	Over run error occurred. A part of the data was lost for some reasons because new data were received before processing previous data. And, this error doesn't usually happen.
513	RS-232 parity error	A parity error occurred. Confirm that Setting of baud rate, the data bit length and the parity are right.
521	Input buffer overflow	A program message exceeded input buffer capacity (1024 characters). Because of this reason, the part which exceeded it was lost.
522	Output buffer overflow	Since one set of response messages exceeded output buffer capacity (1024 characters), the response message was destroyed. Divide a query and receive response for every query.

**[Relations with the standard event status]**

Relations between the four-error bit in the standard event status register and the error number are as follows:

CME (Command error)	: -100 to -199
EXE (Execution error)	: -200 to -299
DDE (Device inherent error)	: -300 to -399 and 500 to 599
QYE (query error)	: -400 to -499

## 5.9 Reading out measured data

There are three methods of reading measured data.

- Reading latest measured data
- Sending measured data in a certain interval
- Reading measured data after memory

Data memory is not mentioned here.

 Refer to " 5.10 Operation of data memory ".

### a) Operation of reading out latest measured data

The operation is executed in following procedures.

- Setting kinds of measured data to be output ( OTYP primary data, secondary Data, ... )  
It can be chosen from (Line number,) DATA1, DATA2, FREQ, SENSITIVITY, OVERLEVEL.  
And also can be selected in operator's disposal.  
It is possible to specify the same data plurally, up to 6 kinds.
- Query measured data ( DOUT?)
- Receive response message  
Line number always stays at zero.

### b) Operation of transmission at constant interval

To be operated as following procedure.

- Set kinds of output measurement data ( OTYP first data , second data ... )
- Set sampling interval for output ( OSMF sampling interval 0.1s to 10000.0s)
- Prepare for output of measurement data (DSTR 1)
- Execute trigger ( transmit \*TRG or GET ), TRIG IN at rear panel is not available.
- Receive response message  
Line number starts from zero, and increases at every sample.
- Stop the output of measurement data. (DSTR 0 )

### c) Syntax of response message

Measured data are produced in separation by comma in the order to be specified when setting the kinds of output measured data.

DATA1, DATA2 and FREQ are output in the form of accordance with panel display.

For example, 0.0001E-0.3, -1.2345E-03 and 10.000E+03 are output to OTYP 1, 2 and 3.

Corresponding to the selection of the voltage and current at that time, the response to SENSITIVITY becomes the same integer of 0 to 26 as the response to VSEN? or ISEN? which is an inquiry of sensitivity.

The response to OVERLEVEL is the same integer as the response to over level condition register query OVCR?.

## 5.10 Operation of data memory

### 5.10.1 Outline of data memory

In case of LI5640, GPIB data transmitting speed is not always enough compared with minimum time constant. Also the lowest data transmitting speed is not guaranteed, and it is difficult to keep constant transmitting speed too.

Therefore in order to measure quick change signals, the function of transmitting to outside after registering measured data in memory is available.

Recording speed to data memory is max.16k sample/s

No back-up data memory. All data memory is cleared after cutting power off.

In case of measuring slow change speed signals, it is not necessary to use data memory. It is more convenient to read out measured data from LI5640 and input them to computer directly every constant time or at only required cases.

In case of setting items related to only data memory, all are to be operated through external interface ( GPIB or RS-232 )

The operation from panel is not available. And recorded data can't be confirmed on panel.

Recorded data is utilized by transmitting to computer through external interface.

Followings as main program message headers related to the data memory operation.

DTYP	Setting kind of data which are recorded in data memory
DSIZ	Setting recording length of data memory ( setting of the dividing number )
DNUM	Specifying number of recording data memory
DSMP	Setting sampling frequency to be recorded in data memory
TENB	Admit / prohibit of rear panel external trigger input
*TRG	Generate trigger signal
STRT	Start ready for recording into data memory
STOP	Stop of recording into data memory (stop)
SPTS?	Query of recorded sampling frequency in data memory
DASC?	Query of data memory contents ( read out in ASCII string )
DBIN?	Query of data memory contents ( read out in binary )

### 5.10.2 Preparation of recording to data memory

It is necessary to specify following parameters when recording measured data in data memory.

#### a) Kinds of data to be recorded in data memory DTYP 0 to 5

Either of following 6 kinds is designated.

- DATA1 ( 1 data / sample )
- DATA2 ( 1 data / sample )
- DATA1, DATA2 ( 2 data / sample )
- DATA2, AUX IN2 ( 2 data / sample )
- DATA1, DATA2, FREQ ( 4 data / sample, FREQ is reference signal frequency )
- DATA1, DATA2, AUX IN1 and AUX IN2 ( 4 data / sample )

Only reference signal frequency is recorded in resolution of 32 bits, and others in 16 bits.

Frequency corresponds to two data because 16 bits in equivalent express one data.

#### b) Record length of data memory DSIZ 0 to 5

Data memory can be used as one block, or plural blocks which are divided equally.

When specifying record length ( block length ), data memory is equally divided according to record length. Recording to data memory terminates after only specified block length's data is recorded.

Total capacity : 64K data ( 16 bits/data , 1K: 1024 )

Record length : 2K data (32 blocks ), 4K data ( 16 blocks ), 8K data ( 8 blocks ),

16K data ( 4 blocks ), 32K data ( 2 blocks ), 64K data ( 1 block )

For example, when DATA1 and DATA2 are recorded by record length 2K data, 1K data is recorded (1024 sampling points).

#### c) Data memory number DNUM 0 to 31

Specify block to be used. The number of data memory starts from zero. When record length is 2k data, the range of number is 0 to 31. In case of no division, specify zero.

#### d) Sampling period of data memory DSMP 0 to 18

Sampling data can be selected in the range of  $62.5 \mu\text{s}$  ( =  $1/16\text{ms}$  ) to 20s.

It is also possible to record one sample at every trigger which is given from the outside( DSMP 0 ).

However there is a certainty of about  $62.5 \mu\text{s}$  between external trigger and real sampling point. Any of followings are available for trigger (Start of record, or record of one sample.).

- Fall edge of TTL level square waveform which input to TRIG IN connector at rear pane.  
It is necessary to admit rear panel external trigger input
- \*TRG command message
- GET ( Group Execute Trigger ) interface message

### 5.10.3 Start of recording into data and termination of detection

In case of starting record into data memory, command of trigger ( \*TRG or GET ) is transmitted after START command is transmitted. GET is not program message.

 About GET ➡ refer to "5.11. Response to interface message".

If an external trigger input is permitted (TENB), record can be started by applying a trigger signal into the TRIG IN connector of the rear panel, or sending the command ( \* TRG or GET) of a trigger by the external interface.

If an external trigger signal is forbidden (TENB0), the trigger command ( \* TRG or GET) of an external interface will start record.

Only record length which is set is recorded and then terminates the record.

When operators want to stop recording on the way, stop command (STOP) should be transmitted.

It is possible to query the number of samples by SPTS? Query, which are actually recorded in the blocks with specified memory numbers.

Record start command under recording into data memory is ignored. When there is possibility of under recording, stop recording forcedly by stop command (STOP), or transmit STRT command after confirming of not under recording by MES bit of operation condition register.

In case of commanding to record 1 sample at every trigger( DSMP 0 ), trigger signal is input to TRIG IN connector at the rear panel after starting to record by STRT command, or transmit the command of trigger ( TRG or GET ) by external interface.

It is simple to use \*WAI command for reading out the contents of data memory at the end of record. The execution after query until the end of record will be waited when command or query is transmitted in following order.

- Prepare for starting record by STRT
- Start to record actually by \*TRG command ( or GET )
- Command to make the execution of next query delay until ending the record by \*WAI command.
- Query data by DASC? or DBIN? ( query of data memory's contents )

 For details, ➡ please refer to "5.13 GPIB sample program"

For recognizing the end of record into data memory, or waiting until the end of record, there are following methods including \*WAI command.

- Make the execution of next command wait by \*WAI command.
- Make response message 1 return at ending record by \*OPC ? query.  
When specified in talker, output 1 is provided after ending record.
- As MAV bit of status bite resister is set by \*OPC? query, MAV bit is polled by serial poll. ( read out orderly )
- While setting MAV bit, transmit service request ( SRQ ) at the end of record with setting responding bit of service request enable to 1.
- Specify to set OPC bit of standard event status resister to 1 at ending record by \*OPC command and poll OPC bit by serial poll.
- While setting OPC bit, transmit service request ( SRQ ) at the end of record with setting ESB bit of service request enable resister to 1.
- Poll MES bit of operation condition resister ( under record into data memory ) by OPCR? query.
- Poll MES bit of operation event resister ( ending record into data memory ) by OPER? query.
- Through setting MES bit of operation enable resister and OSB bit of service request enable resister to 1, transmit service request at the end of record.

 About resister related to various status and service request

➡ Refer to "5.3 service request and status structure".

In addition: Recording into data memory will be stopped in case of following operations.

- Setting displayed parameters, kinds of data to be recorded, record length, or data memory numbers.
- Start of continuous data output
- Query of latest measurement data.

Data memory will be cleared in case of following operations

- Setting kinds of data to be recorded or record length
- \*RST command

### 5.10.4 Reading out data memory

Operate by following procedure for reading out data memory.

- Specify the number of reading out data memory ( from 0 )  
( DNUM number of data memory )
- Query the number of recorded samples actually when making stop on the way.  
( SPTS? → 1024 (an example) )
- Query contents of data memory after specifying samples to be read out.  
( DASC? Sample position for starting to read out ( from 0 ), numbers of read out samples)
- Receive response message.

It is possible to read out partially data which is already recorded even if blocks under recorded.

DASC? query is used in case of reading out in ASCII letter row.

When read out in binary, DBIN? is used instead of DASC?

Format of response message is as below

- Response to DASC? ( ASCII )  
According to data's kinds to be recorded in data memory, integers which show each measured value ( punctuated by comma if plural ) are put into output in described order on the table.  
First data, second data, ... terminator ( ←first sample )  
First data, second data, ... terminator ( ←second sample )  
... Only specified samples are put into output ...  
Each data shows integer equivalent to 16 bit ( approx.  $\pm 2^{15}$  ) or 32 bit (approx.  $\pm 2^{31}$ ) is converted into ASCII letter row (figure ).
- Response to DBIN? ( Binary )  
The order for output is the same as ASCII letter row output, but output is provided in binary of 16 bits or 32 bits ( 2's complement ). The output of comma, or terminator is not available.  
The output starts from upper bytes in order out of one data.  
End message is output with final data ( byte ).

Relation between each data and parameters are shown as below.

- X, Y, R, NOISE, AUX IN1, AUX IN2

Data is output as 16 bits integer ( 2's complement )

Actual value is calculated in following formula.

$$\text{Parameter value} = \text{output data} \times 2^{-15} \times 1.2 \times \text{meter full scale}$$

Meter full scale is as below

X, Y, R : sensitivity X EXPAND multiply

RATIO : 2

dB : 100 dB

% : 200 %

AUX IN1 : 10 V

AUX IN2 : 10 V

For example, if output data is 12345 in case of measuring R by sensitivity 10mV, actual value is as follows.

$$12345 \times 2^{-15} \times 1.2 \times 10\text{mV} = +4.521 \text{ mV}$$

- Phase(  $\theta$  )

Data is output as 16 bit integer ( 2's complement ).

Actual value is calculated in following formula.

$$\text{Phase} = \text{output data} \times 2^{-16} \times 360^\circ$$

- Reference signal frequency ( FREQ )

Data is output as 32 bit integer ( 2's complement )

Actual value is calculated in following formula.

$$\text{Frequency} = \text{output data} \times 2^{-32} \times 256 \text{ kHz.}$$

## 5.11 Response to interface message

LI5640 response to interface message is shown on following table.

**Table 5-8 Response to interface message**

IFC	<Interface Clear> Initializes GPIB interface. Releases specified listener and talker.
DCL SDC	<Device Clear > <Selected Device Clear> Clears input buffer, and aborts interpretation and execution of command. Clears output queue, and clear bit 4 ( MAV ) of status byte register. Releases hold off of over-wrap command by WAI, *OPC command.
LL0	<Local Lockout> Disables operation of front panel SHIFT + LOCAL key.
GTL	<Go to Local> Puts the system in a local status.
GET	<Group Execute Trigger> Execute trigger. It works in the same way as TRG command message.

The use of interface message varies with the GPIB driver on the controller side.

For details, refer to the manual for the GPIB driver.

## 5.12 Initialization of GPIB

Generally, in external control, the state of the equipment when performing a program is unknown. For this reason, initial setting is required before sending the command and query from an actual operates equipment. A following interface message and a following command are mainly used for initial setting.

- Interface clear (IFC)
- device clear (DCL, SDC)
- reset (\*RST)
- clear status (\*CLS)

### a) Interface clear (IFC)

This interface message initializes fundamental interface functions of a bus, such as canceling listener and talker.

In some GPIB driver of a controllers, when declaration of using GPIB, the interface message IFC is sent automatically. Otherwise, it is necessary to send IFC clearly using the command which sends IFC of a GPIB driver.

### b) Device clear (DCL, SDC)

This interface message clears the input buffer and output cue in which the contents may remain by error etc. Moreover, hold-off of overlap command is canceled. And LI5640 is enabled to execute the following command.

Although there are some equipment which changes with device clear to a specific setup, the setup does not change in LI5640.

☞ IFC, DCL, and SDC → Refer to "5.11 Response to an interface message"

### c) Reset (\*RST)

Equipment is returned to the state where the INIT command was executed, and a data memory is cleared. Moreover, execution of \*OPC command and \*OPC? query is canceled, and it is made not to perform the set of OPC bit, and the return of "1" at the end of a command.

### d) Clear status (\*CLS)

Program message \*CLS clears the event register and error code cue of a status system. Moreover, execution of \*OPC command and \*OPC? query is canceled, and it is made not to perform the set of OPC bit, and the return of "1" at the end of a command.

The \*CLS command does not clear an enable register. It is more safe to use \*CLS command after carrying out the zero clear of all the bits of enable register, and to use \*CLS command, in order to suppress generating of a new event. Then, enable register is set up if needed.

The \*CLS command clears a status byte indirectly except for a MAV bit and a RQS bit. MAV bit is clearable by device clear. RQS bit is clearable by performing one time of a serial pole.

It is forgotten to clear the RQS bit in many cases. For this reason, when a service request (SRQ) occurs, it is problem to check generating of a factor only in a RQS bit. After checking generating of the event used as the factor, it recommends performing corresponding processing.

## 5.13 Sample GPIB program

### 5.13.1 Outline of sample program

The following section introduces samples of remote control that uses GPIB interface.

Here, the following case is shown:

- Case where Microsoft's Visual Basic and National Instruments' GPIB interface board are Used.

The description here will focus on the following six types of remote control.

#### a) Setup and Query

This is the simplest type of remote control. After initialization, the amplitude of the oscillator is set, and then it is confirmed by running a query.

#### b) Query of measurement data

After simple setting, conduct query of measurement data repeatedly.

#### c) Auto setting ( AUTO SET)

Start auto setting ,and then measure after the end of it.

#### d) Record in data memory and read out (ASCII)

Start to record in data memory, and read out data after confirming the end of record.  
ASCII format is used for reading out from data memory.

#### e) Use of SRQ

The over level is detected by using SRQ.

#### f) Record in data memory and read out ( BINARY)

Measurement data in data memory is recorded and read out in the same as  
"d) Record in data memory and read out (ASCII)". Binary format is used for reading out.

In any cases, error check and etc. are abbreviated.

Please take care for error processing and initialization procedure when preparing a practical program.

### **5.13.1 Case where Visual Basic and National Instruments' GPIB Interface board are used.**

When using National Instruments' GPIB interface board and driver software, it is necessary to add characters expressly because EOS characters are not added automatically in sending characters string.

When receiving a response message( `ibrd` ), the number of received characters are limited to the receiving buffer length. Sample program in this case uses fixed length character string. In case of using variable length character string, it is necessary to secure receiving buffer length by space ( ), etc. in front of `ibrd`.

The number of reception characters is obtained by global variable `ibcnt`.

### a) Setting and query

If the button is pressed, voltage sensitivity is set and result of query is displayed.

Necessary initialization is executed by load of form.

Here, the device descriptor ( Dev ) is opened with the timeout of 300 ms, GPIB address 2, EOI valid and terminator LF.

In SetQueryBtn, the command of setting voltage sensitivity is transmitted to the device in parameters that are converted from input character string to SetValueTxt.

Terminator at transmission is required to be added by program code.

In form unload, the device should be returned in local condition.

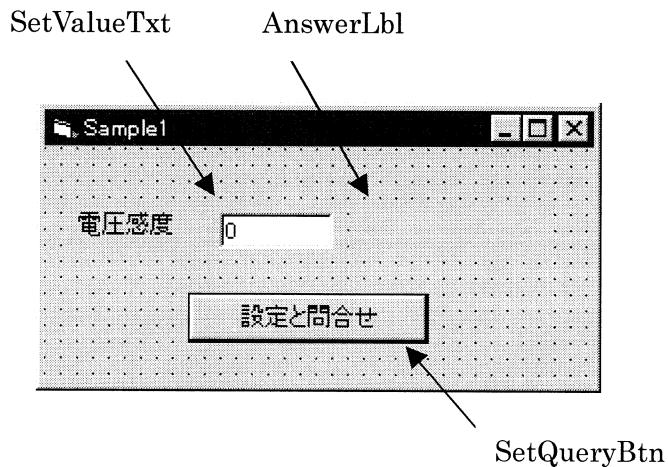

```

Const ADR As Integer = 2           ' GPIB address
Const EOSCHAR As Integer = &HA    ' specify LF at terminator
Const EOS As Integer = XEOS + REOS + EOSCHAR
Dim Dev As Integer

Private Sub Form_Load()
    ibdev 0, ADR, 0, T300ms, 1, EOS, Dev    ' device open
    ibclr Dev                               ' device clear
End Sub

Private Sub Form_Unload(Cancel As Integer)
    ibloc Dev                               'Go to Local
    ibonl Dev, 0                            'Device off line set
End Sub

Private Sub SetQueryBtn_Click()
    Dim rdbuf As String * 256
    ibwrt Dev, "VSEN " & SetValueTxt & Chr(EOSCHAR) ' set voltage sensitivity
    ibwrt Dev, "VSEN?" & Chr(EOSCHAR)             ' query voltage sensitivity
    ibrd Dev, rdbuf                                ' receive response message
    AnswerLbl = Left(rdbuf, ibcnt)
End Sub

```

## b) Query of measurement data

When pressing the button, measurement data is repeatedly displayed.

In this case, terminator is not specified, only EOI is available.

When pressing StartStopBtn after specifying measurement data at setting initialization, measurement data is displayed with querying every 500 ms by Timer 1

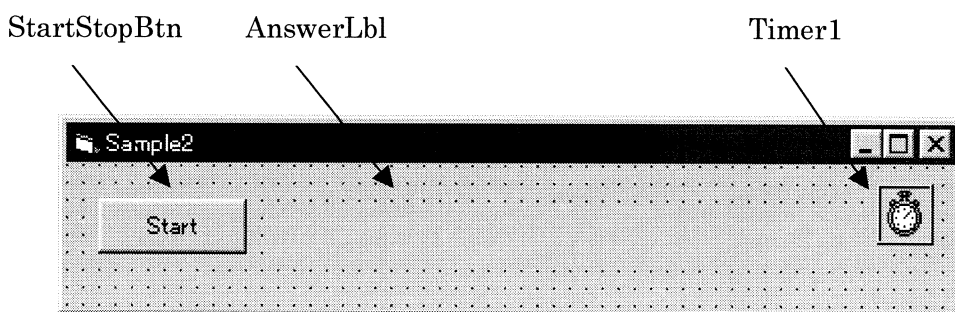

```

Const Adr As Integer = 2
Dim Dev As Integer

Private Sub Form_Load()
    ibdev 0, Adr, 0, T300ms, 1, 0, Dev          'Device open
    ibclr Dev                                   'Device clear
    ibwrt Dev, "OTYP 1,3,5"                   'Specify measurement data
    Timer1.Enabled = False
    Timer1.Interval = 500
End Sub

Private Sub Form_Unload(Cancel As Integer)
    ibloc Dev                                  'Go to Local
    ibonl Dev, 0                               'setting device offline
End Sub

Private Sub StartStopBtn_Click()
    If StartStopBtn.Caption = "Start" Then
        Timer1.Enabled = True                 ' start repeat
        StartStopBtn.Caption = "Stop"
    Else
        Timer1.Enabled = False               ' stop repeat
        StartStopBtn.Caption = "Start"
    End If
End Sub

Private Sub Timer1_Timer()
    Dim buf As String * 256
    ibwrt Dev, "DOUT?"                       ' Query of measurement data

    ibrd Dev, buf                             ' Receive response message

    AnswerLbl = Left(buf, ibcnt)
End Sub

```

## c) Auto setting

When pressing the button, Auto setting( AUTO SET ) is executed, and measurement data is displayed.

When transmitting \*WAI command, any command is not executed until terminating all executions of over wrap command before then.

In this case, query of measurement data (DUT?) is not executed until the end of auto setting.

This is specified by initialization for avoiding time out before the termination of auto setting(TONE).

While waiting for the end of execution by \*WAI, software can't be performed.

Using polling or SRQ, other processing is performed during end is waited.

☞ Example of polling ➡ Refer to " d) Record to data memory and read out (ASCII)".

☞ Example of SRQ ➡ Refer to " e) Use of SRQ".

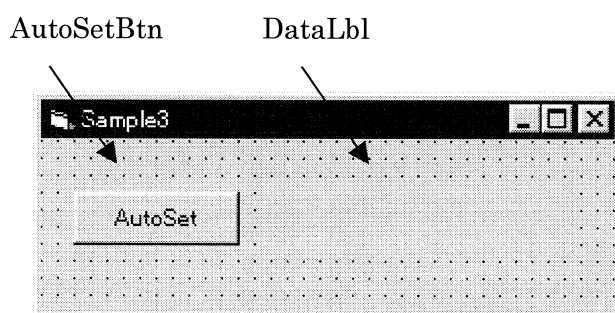

```

Private Sub Form_Load()
    ibdev 0, Adr, 0, TNONE, 1, 0, Dev           ' Device open
    ibclr Dev                                   ' Device clear
End Sub

Private Sub AutoSetBtn_Click()
    Dim rdbuf As String * 256
    AutoSetBtn.Enabled = False
    DataLbl = "Start Auto Set"
    DataLbl.Refresh
    ibwrt Dev, "ASET; *WAI"                    ' Start Auto setting
    ibwrt Dev, "DOUT?"                        ' Query of measurement

    ibrd Dev, rdbuf
    DataLbl = Left(rdbuf, ibcnt)
    AutoSetBtn.Enabled = True
End Sub

```

d) Record and read-out to the data memory (ASCII )

The pressing on the button executes the start of recording to data memory and reading out after the end of record. Read out data can be displayed by operating scroll bar.

For examining the end of record to data memory, query repeatedly contents of operation event register by the timer.

The press on StartBtn executes the start of record by various settings. The end of record should be clear before starting because it is examined by operation event register.

After starting to record, the contents of operation event register are examined (Polling) every 500 ms by the timer, and the end is waited. During this time, software is available for other processing. Here, for performance confirmation of the timer, "\*" and "+" are displayed alternatively on DataLbl.

After confirming the end of record, data memory is read out in ASCII format by BlockRead routine. Read out data is stored in DataValue ( ).

It is also possible to use SRQ for recognizing the end of record.

 Example of using SRQ → Refer to " e) Use of SRQ".

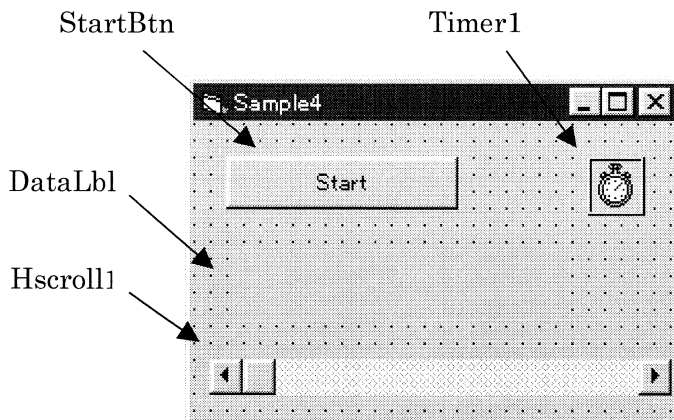

```

Dim Dev As Integer
Const Adr As Integer = 2           ' GPIB address

Dim DataCount As Long
Dim DataValue(2048) As Integer

Private Sub Form_Load()
    ibdev 0, Adr, 0, T300ms, 1, 0, Dev    'Device open
    ibclr Dev                             ' Device clear
End Sub

Private Sub Form_Unload(Cancel As Integer)
    ibloc Dev                             'Go to Local
    ibonl Dev, 0                          ' Setting device off line
End Sub
    
```

```

Private Sub StartBtn_Click()
    StartBtn.Enabled = False
    HScroll1.Enabled = False
    DataLbl = "Start Measure"
    DataCount = 0
    ibwrt Dev, "*CLS" ' Event register clear
    ibwrt Dev, "DSIZ 0; DNUM 0; DTYP 0;" ' Specify record length, memory number, data
    ibwrt Dev, "DSMP 6; STRT; *TRG" ' Specify frequency and measurement start
    Timer1.Interval = 500
    Timer1.Enabled = True
End Sub

Private Sub Timer1_Timer()
    Dim rdbuf As String * 256
    ibwrt Dev, "OPER?" ' Query of operation event register
    ibrd Dev, rdbuf
    rdbuf = Left(rdbuf, ibcnt)
    If Left(DataLbl, 1) = "*" Then DataLbl = "+ " & rdbuf Else DataLbl = "* " & rdbuf
    If Cint(rdbuf) And 16 Then
        Timer1.Enabled = False
        BlockRead
        HScroll1.Max = DataCount - 1
        HScroll1.Enabled = True
        HScroll1 = 1: HScroll1 = 0
        StartBtn.Enabled = True
    End If
End Sub

Private Sub BlockRead()
    Dim i As Integer
    Dim rdbuf As String * 256
    ibwrt Dev, "SPTS?" ' Query of recorded sampling frequency
    ibrd Dev, rdbuf
    DataCount = Val(Left(rdbuf, ibcnt))
    ibwrt Dev, "DASC? 0," & CStr(DataCount) ' Read out data memory (ASCII)
    For i = 0 To DataCount - 1
        ibrd Dev, rdbuf
        DataValue(i) = Cint(Left(rdbuf, ibcnt))
        DataLbl = CStr(i + 1) & "/" & CStr(DataCount)
        DataLbl.Refresh
    Next
End Sub

Private Sub HScroll1_Change()
    DataLbl = CStr(HScroll1) & ": " & DataValue(HScroll1)
End Sub

```

## e) Use of SRQ

This case shows Over level is detected by using SRQ.

When over level occurs, OverShp ( round shaped control ) turns on red light. In case of resetting, ClearBtn should be pressed.

GPIBNotify control is used for observing SRQ and causing event.

GPIBNotify control can be used if selecting gpibNotify [OLE Module] out of components of Project menu in Visual Basic.

In event procedure( SRQNotify-Notify)that starts by SRQ, over level is detected by Querying serial poll and over level event register.

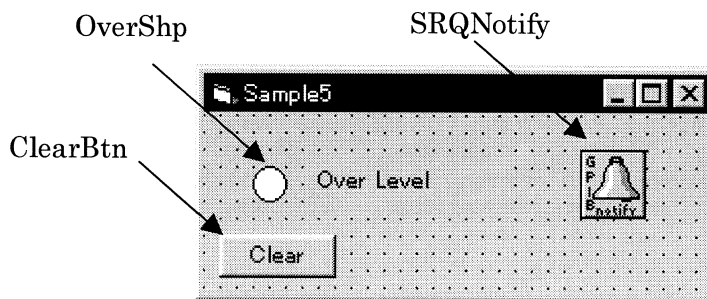

```

Const ADR As Integer = 2
Dim Dev As Integer

Private Sub Form_Load()
    Dim stat As Integer
    ibdev 0, ADR, 0, T300ms, 1, 0, Dev           'Device open
    ibclr Dev                                   'Device clear
    ibwrt Dev, "**SRE 1; OVEE 1"                 'Setting enable register for SRQ

    stat = SRQNotify.SetupNotify(Dev, RQS)      'Setting observation of SRQ
End Sub

Private Sub SRQNotify_Notify(ByVal LocalUD As Long, ByVal LocalIbsta As Long, ByVal
LocalIberr As Long, ByVal LocalIbcntl As Long, RearmMask As Long)
    Dim stb As Integer
    Dim rdbuf As String * 256
    If (LocalIbsta And RQS) Then                 'confirmation of RQS event
        ibrsp Dev, stb                          'Serial poll
        If (stb And 1) Then                     'Checking the cause of RQS event
            ibwrt Dev, "OVER?"                  'Query of over level event register
            ibrd Dev, rdbuf
            If (CInt(Left(rdbuf, ibcntl)) And 1) Then
                OverShp.FillColor = &HFF&      ' Detection of over level
            End If
        End If
        RearmMask = RQS                          ' resetting SRQ observation
    End If
End Sub

Private Sub ClearBtn_Click()
    OverShp.FillColor = &HFFFFFF
End Sub

```

## f) Record and read-out to the data memory (Binary )

As the same as "d) Record and read-out to the data memory (ASCII)", measurement data is recorded into the data memory, or is read from the data memory. However, binary form is available for reading out.

It is the same as "d) Record and read-out to the data memory" except BlockReadBin and ByteSwap.

In BlockReadBin, data memory is directly read into integer array DataValue( ). In transmitting binary, byte's order is reversely stored in integer array because of transmitting in order from upper byte to lower byte. Correct data is derived through swapping upper and lower of each data by ByteSwap.

ByteSwap is more speedy in arithmetic way, but here 16 character string operation is introduced for easier understanding.

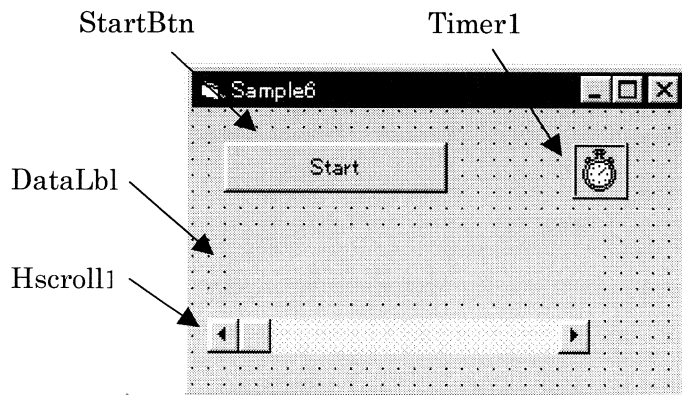

```

Dim Dev As Integer
Const ADR As Integer = 2           ' GPIB address
Dim DataCount As Long
Dim DataValue(2048) As Integer

Private Sub Form_Load()
    ibdev 0, ADR, 0, 0, 1, 0, Dev   ' Device open
    ibclr Dev                       ' Device clear
End Sub

Private Sub Form_Unload(Cancel As Integer)
    ibloc Dev                       ' Go to Local
    ibonl Dev, 0                   ' setting device off line
End Sub

Private Sub StartBtn_Click()
    StartBtn.Enabled = False
    HScroll1.Enabled = False
    DataLbl = "Start Measure"
    DataCount = 0
    ibwrt Dev, "*CLS"               ' event register clear
    ibwrt Dev, "DSIZ 0; DNUM 0; DTYP 0;" ' Specify record length, memory No. data
    ibwrt Dev, "DSMP 6; STRT; *TRG" ' Specify frequency and measurement start
    Timer1.Interval = 500
    Timer1.Enabled = True
End Sub

```

```

Private Sub Timer1_Timer()
    Dim rdbuf As String * 256
    ibwrt Dev, "OPER?" ' Query of operation event register
    ibrd Dev, rdbuf
    rdbuf = Left(rdbuf, ibcnt)
    If Left(DataLbl, 1) = "*" Then DataLbl = "+ " & rdbuf Else DataLbl = "* " & rdbuf
    If CInt(rdbuf) And 16 Then
        Timer1.Enabled = False
        BlockReadBin
        HScroll1.Max = DataCount - 1
        HScroll1.Enabled = True
        HScroll1 = 1: HScroll1 = 0
        StartBtn.Enabled = True
    End If
End Sub

Private Sub BlockReadBin()
    Dim rdbuf As String * 256
    ibwrt Dev, "SPTS?" ' Query of recorded number of sampes
    ibrd Dev, rdbuf
    DataCount = Val(Left(rdbuf, ibcnt))
    ibwrt Dev, "DBIN? 0," & CStr(DataCount) ' Read out data memory (Binary )
    ibrdi Dev, DataValue(), DataCount * 2
    ByteSwap DataValue(), DataCount
End Sub

Private Sub ByteSwap(dt() As Integer, n As Long)
    Dim t As String
    Dim i As Long
    For i = 0 To n - 1
        t = Right("000" & Hex(dt(i)), 4)
        dt(i) = CInt("&h" & Right(t, 2) & Left(t, 2))
    Next
End Sub

Private Sub HScroll1_Change()
    DataLbl = CStr(HScroll1) & ": " & DataValue(HScroll1)
End Sub

```

Information Multi-line Interface Messages

*2				b7	0	*1	0	0	0	0	1	1	1	1	1	1	1												
				b6	0	MSG	0	MSG	1	MSG	0	MSG	0	MSG	1	MSG	1												
				b5	0		1		0		0		0		0		1												
b4	b3	b2	b1	Column	0		1		2		3		4		5		6		7										
				ROW																									
0	0	0	0	0	NUL		DLE		SP	↑	0	↑	@	↑	P	↑	`	↑	p	↑									
0	0	0	1	1	SOH	GTL	DC1	LLO	!	↑	1	↑	A	↑	Q	↑	a	↑	q	↑									
0	0	1	0	2	STX		DC2		"	↑	2	↑	B	↑	R	↑	b	↑	r	↑									
0	0	1	1	3	ETX		DC3		#	↑	3	↑	C	↑	S	↑	c	↑	s	↑									
0	1	0	0	4	EOT	SDC	DC4	DCL	\$	↑	4	↑	D	↑	T	↑	d	↑	t	↑									
0	1	0	1	5	ENQ	*3 PPC	NAK	PPU	%	↑	5	↑	E	↑	U	↑	e	↑	u	↑									
0	1	1	0	6	ACK		SYN		&	↑	6	↑	F	↑	V	↑	f	↑	v	↑									
0	1	1	1	7	BEL		ETB		'	↑	7	↑	G	↑	W	↑	g	↑	w	↑									
1	0	0	0	8	BS	GET	CAN	SPE	(	↑	8	↑	H	↑	X	↑	h	↑	x	↑									
1	0	0	1	9	HT	TCT	EM	SPD	)	↑	9	↑	I	↑	Y	↑	i	↑	y	↑									
1	0	1	0	10	LF		SUB		*	↑	:	↑	J	↑	Z	↑	j	↑	z	↑									
1	0	1	1	11	VT		ESC		+	↑	:	↑	K	↑	[	↑	k	↑	{	↑									
1	1	0	0	12	FF		FS		,	↑	<	↑	L	↑	*4 ]	↑	l	↑		↑									
1	1	0	1	13	CR		GS		-	↑	=	↑	M	↑	]	↑	m	↑	}	↑									
1	1	1	0	14	SO		RS		.	↑	>	↑	N	↑	^	↑	n	↑	~	↑									
1	1	1	1	15	SI		US		/	↓	?	↓	UNL	↓	_	↓	UNT	↓	o	↓									
					Address Command Group (ACG)					Universal Command Group (UCG)					Listener Address Group (LAG)					Talker Address Group (TAG)									
										Primary Command Group (PCG)										Secondary Command Group (SCG)									

Note: \*1 MSG is an interface message

\*2 b1=DIO1 ... b7=DIO7. DIO8 is not used.

\*3 Involves a secondary command

\*4 “\” in IEC standard; “¥” in JIS

GTL: Go To Local

SDC: Selected Device Clear

PPC: Parallel Poll Configure

GET: Group Execute Trigger

TCT: Take Control

LLO: Local Lockout

DCL: Device Clear

PPU: Parallel Poll Unconfigure

SPE: Serial Poll Enable

SPD: Serial Poll Disable

UNL: Unlisten

UNT: Untalk

